

Instructions for: Vestil Step Stools

The guide on the following page(s) was provided by the supplier. New Pig Corporation assumes no responsibility, obligation, or liability in conjunction with the use or misuse of the information.



New Pig

One Pork Avenue
Tipton, PA 16684-0304

newpig.com

North America: **1-800-468-4647**

Europe: **+31 (0)76 596 92 50**

China: **+86-21-400 921 5178**

UK: **0800 919 900**

Outside North America: **+1-814-684-0101**

PIG, PIG logo are registered trademarks in USA and other countries. See tm.newpig.com

365374



Vestil Manufacturing Corp.

2999 North Wayne Street, P.O. Box 507, Angola, IN 46703
 Telephone: (260) 665-7586 -or- Toll Free (800) 348-0868
 Fax: (260) 665-1339
 Web: www.vestilmfg.com e-mail: info@vestil.com

VST-4-Y

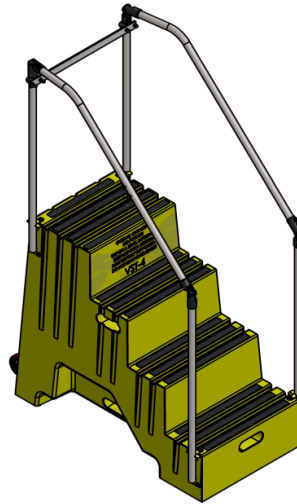

Receiving Instructions

After delivery, remove the packaging from the product. Inspect the product closely to determine whether it sustained damage during transport. If damage is discovered, record a complete description of it on the bill of lading. If the product is undamaged, discard the packaging.

NOTE: The end-user is solely responsible for confirming that product design, use, and maintenance comply with laws, regulations, codes, and mandatory standards applied where the product is used.

Technical Service & Replacement Parts

For answers to questions not addressed in these instructions and to order replacement parts, labels, and accessories, call our Technical Service and Parts Department at (260) 665-7586. The Department can also be contacted online at <https://www.vestil.com/page-parts-request.php>.



Electronic Copies of Instruction Manuals

Additional copies of this instruction manual may be downloaded from <https://www.vestil.com/page-manuals.php>.

Table of Contents	Page
Signal Words.....	2
Safety Instructions.....	2 - 3
Specifications.....	3
Exploded View and Bill of Materials.....	4
Assembling the Steps.....	5, 6, 7
Using the Steps.....	7
Record of Satisfactory Condition.....	8
Inspections & Maintenance.....	8
Labeling Diagram.....	9
Limited Warranty.....	10

SIGNAL WORDS

SIGNAL WORDS appear in this manual to draw the reader's attention to important safety-related messages. The following are signal words used in this manual and their definitions.

 DANGER	Identifies a hazardous situation which, if not avoided, WILL result in DEATH or SERIOUS INJURY . Use of this signal word is limited to the most extreme situations.
 WARNING	Identifies a hazardous situation which, if not avoided, COULD result in DEATH or SERIOUS INJURY .
 CAUTION	Indicates a hazardous situation which, if not avoided, COULD result in MINOR or MODERATE injury.
NOTICE	Identifies practices likely to result in product/property damage, such as operation that might damage the product.

SAFETY INSTRUCTIONS

Vestil strives to identify hazards associated with the use of its products, but no manual can address every conceivable risk. Minimize the likelihood of injury by recognizing the hazards identified below and by inspecting and maintaining the product as instructed in [INSPECTIONS & MAINTNENANCE](#) on p. 8.

WARNING

Hazardous conditions could result in serious personal injuries or death.

- **Read and understand the entire manual before assembling, using, inspecting, or servicing the steps.**
- **DO NOT use the steps unless you are in good health. NEVER use the steps while under the influence of alcohol or drugs, including prescription medication that affects balance, perception, or judgment.**
- DO NOT exceed the capacity/rated load. The total weight applied to the stepstool (weight of the user plus tools, etc.) must not be greater than the capacity indicated on the riser of the top step (500 lb.; 227kg).
- Do not use the unit if the steps are cracked, dented, or damaged in other ways. Do not use the unit unless handrails are solidly fastened to the steps.
- Wear appropriate footwear. DO NOT wear high-heeled shoes or footwear with smooth soles.
- DO NOT use the steps on uneven, sloped, or unstable surfaces. **ONLY use the steps on even, level, improved surfaces (e.g. concrete or asphalt).**
- Make sure that you will not contact overhead objects during use.
- Avoid electrical shock! Take precautions to prevent contact, or possible contact, with an energized, electrical wire/cord.
- Remove dirt and debris from your shoes before walking on the steps. Only wear slip-resistant shoes.
- Only stand on the steps. DO NOT climb on the railing. DO NOT slide on the railing.
- DO NOT step onto, or off of, any step from another elevated surface.
- ALWAYS face the stairs and use the handrails while ascending and descending the stepstool.
- DO NOT increase the height of a step by standing on other objects placed on one of the steps.
- Inspect the steps as described in [INSPECTIONS & MAINTNENANCE](#) on p. 8. DO NOT use the stool unless it is in [SATISFACTORY CONDITION](#). ONLY use manufacturer-approved replacement parts when repairs are necessary. See [RECORD OF SATISFACTORY CONDITION](#) on p. 8.
- DO NOT use the steps if 1 or more of the molded rubber feet (14-145-179) is significantly worn, damaged, or missing. See [EXPLODED VIEW](#) on p. 4. Only use the steps if all 4 feet are in place and are in [SATISFACTORY CONDITION](#).
- ONLY use the steps as standing surfaces. DO NOT use it for any other purpose. DO NOT store materials or equipment on the steps. Always unload the steps before leaving them unattended.
- DO NOT use the steps in front of a door unless the door is secured in an open position, is locked, is attended, or is barricaded.
- DO NOT lean, or reach, over the handrails/sides of the steps. Position the steps as close to the work as possible. Reposition the steps to prevent overreaching. Overreaching could cause instability and result in a fall.
- Avoid sudden shifts while on the steps.
- DO NOT skip steps. Climb the steps one step at a time.
- DO NOT attempt to move the steps while someone is using them.

Continues on next page

EXPLODED VIEW AND BILL OF MATERIALS (14-006-340)

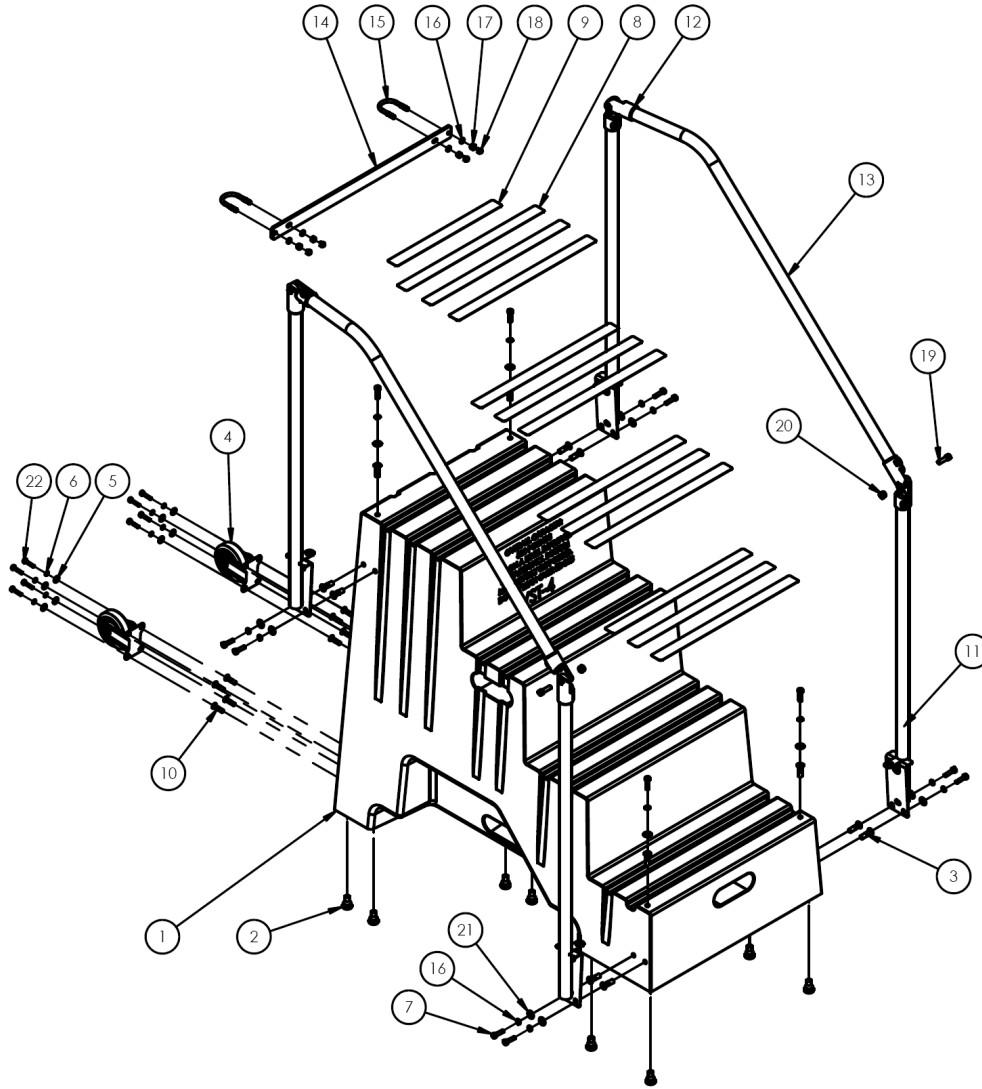

ITEM	PART NO.	DESCRIPTION	QTY.	ITEM	PART NO.	DESCRIPTION	QTY.
1	14-147-035	STEPS, POLYETHYLENE, 4-STEP	1	12	44-516-016	ASSEMBLY, HANDRAIL, PIPE END	8
2	14-145-179	MOLDED FOOT, ANTI-SKID	8	13	14-024-042	GUARD,HANDRAIL TUBE,4-STEP,FORMED	2
3	99-145-197	NUT, EXPANDING INSERT, 4 WING, 5/16-18, .1875-.375 GRIP	12	14	14-017-041	BAR, STIFFENER	1
4	16-132-197-601	CASTER RIGID, Ø4 X 1 1/4, MAROON DURATOUGH POLY	2	15	42024	U-BOLT,5/16"-18 X 1-1/8" THRD LENGTH,FOR 1-3/4" OD	2
5	33004	FLAT WASHER, USS, ZINC PLATED, Ø1/4"	8	16	33620	LOCK WASHER, MEDIUM SPLIT, Ø5/16"	16
6	33618	MEDIUM SPLIT LOCK WASHER, Ø1/4"	8	17	36304	NUT, HEX NUT Z-PLATED, Ø 5/16 - 18	4
7	11057	HEX BOLT, GRADE A, ZINC PLATED, 5/16-18X1.25	12	18	37709	ACORN NUT, Ø 5/16 - 18, GRADE 2	4
8	14-051-015	TAPE, ANTI-SLIP, 20"	12	19	23307	SHCS,UTILITY GRADE,3/8 - 16 x 1 1/4 LG.	4
9	14-051-012	TAPE, ANTI-SLIP, 16"	1	20	37024	NYLON INSERT LOCK NUT, GRADE 2, ZINC FINISH, 3/8"-16	4
10	99-145-196	NUT, EXPANDING INSERT, 4 WING, 1/4-20, .1875-.375 GRIP	8	21	33006	FLAT WASHER,ZINC PLATED,USS, Ø5/16"	12
11	14-524-018	WELDMENT, HANDRAIL POST	4	22	11007	Ø 1/4-20 UNC x 1 1/4 LG HEX BOLT, GRADE A	8

ASSEMBLING THE STEPS

NOTE: Numbers in parentheses () correspond to part numbers in the [BILL OF MATERIALS](#) on p. 4.

Install the handrails, casters (16-132-197), and molded feet (14-145-179) before putting the steps into service. Use a torque wrench to install hardware according to the torque specifications provided in the following instructions.

1. Attach the handrail posts (14-524-018) to the steps (14-147-035) with 5/16"-18 hardware
 - a. Put a 5/16" lock washer (33620) and then a 1/4" flat washer (33004) onto each of 12 bolts (11057). Bolts are 5/16"-18 x 1.25".
 - b. Insert the bolts through the post brackets and top brackets. Wind the bolts into the expanding insert nuts (99-145-197).

NOTE: Expanding insert nuts are installed in the pilot holes in the steps at the factory. Tighten all bolts to 8.8lb-ft with your torque wrench.

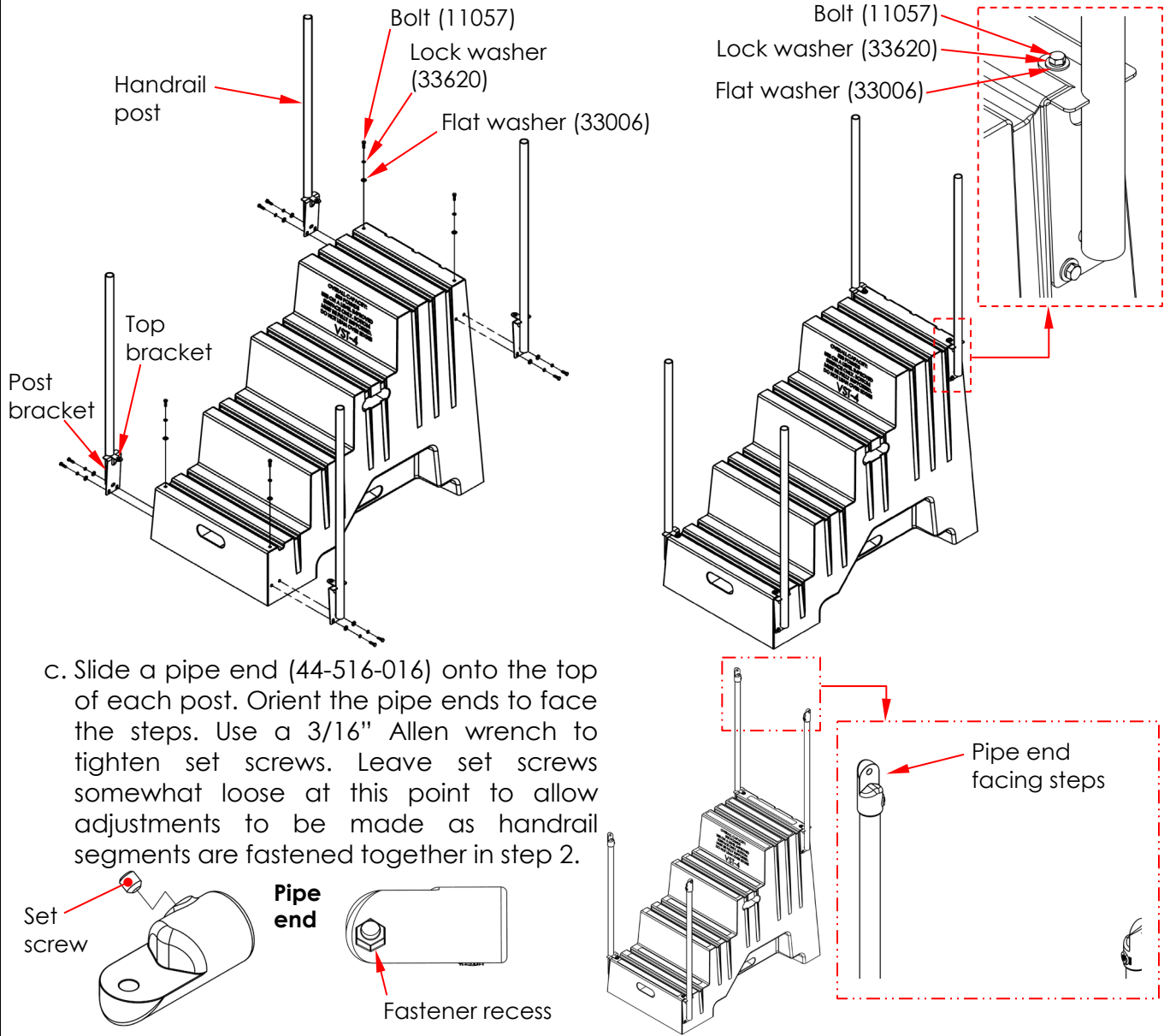

- c. Slide a pipe end (44-516-016) onto the top of each post. Orient the pipe ends to face the steps. Use a 3/16" Allen wrench to tighten set screws. Leave set screws somewhat loose at this point to allow adjustments to be made as handrail segments are fastened together in step 2.

2. Fasten the handrail tubes (14-024-042) to the handrail posts (14-524-018)
 - a. Attach a pipe end to each end of both handrail tubes. Make sure that the pipe ends face away from the steps. See diagram following [step 2c](#) on the next page.
 - b. Put 3/8"-16 lock nuts (37024) in the fastener recesses of the pipe ends connected to the handrail tubes.

c. Align handrail tubes with handrail posts as shown below. Install a 3/8"-16 x 1.25" socket cap screw (23307) through the bolt holes of aligned pipe ends (44-516-016) and wind them into the lock nuts as shown in the diagrams below.

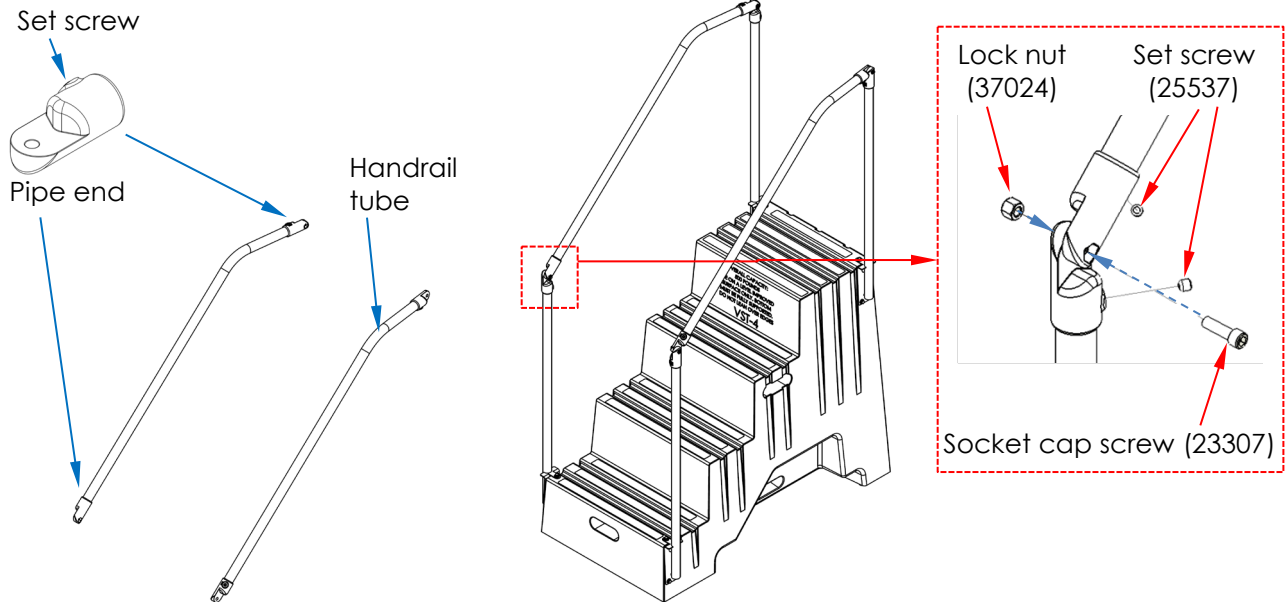

Handrail tubes with pipe ends

Handrail tubes fastened to posts

d. Tighten all 4 socket cap screws to 15.7ft·lb with your torque wrench.

e. Tighten all 8 set screws to 23ft·lb.

3. Install the handrail stabilizer bar (14-017-041) with 5/16" hardware

a. Place the handrail stabilizer against the upper handrail posts. The top edge of the stabilizer should contact the bottoms of the pipe ends.

b. Install the 5/16"-18 x 1 1/8" U-bolts (42024) around the handrail posts and through the bolt holes provided at both ends of the stabilizer bar.

c. Install a 5/16" lock washer (33620) and a 5/16"-18 hex nut (36304) onto each arm of both U-bolts. Tighten all 4 hex nuts to 8.8ft·lb.

d. Install 5/16"-18 acorn nuts (37709) onto both legs of both U-bolts. Tighten each acorn nut to 8.8ft·lb.

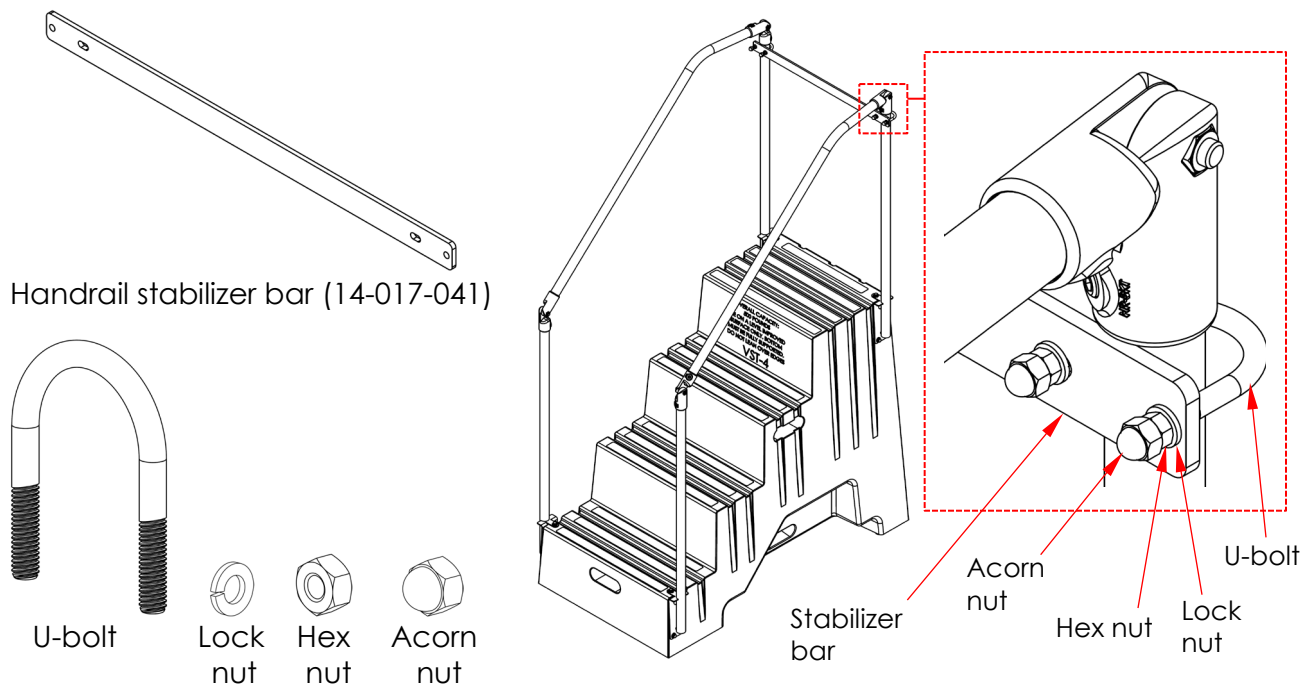

4. **Fasten casters (16-132-197) to the back of the steps with 1/4" hardware**
 - a. Put a 1/4" flat washer (33004) followed by a 1/4" lock washer (33618) onto each of 8 bolts (11007). Bolts are 1/4"-20 x 1.25".
 - b. Eight (8) pilot holes are provided in the rear wall of the steps.
 - c. Fasten each caster to the rear wall with four sets of bolts (11007), flat washers (33004), and lock washers (33618). Insert the bolts through the bolt holes in the caster mounting brackets and wind them into the pilot holes. NOTE: Expanding insert nuts (99-145-196) are preinstalled in the pilot holes.

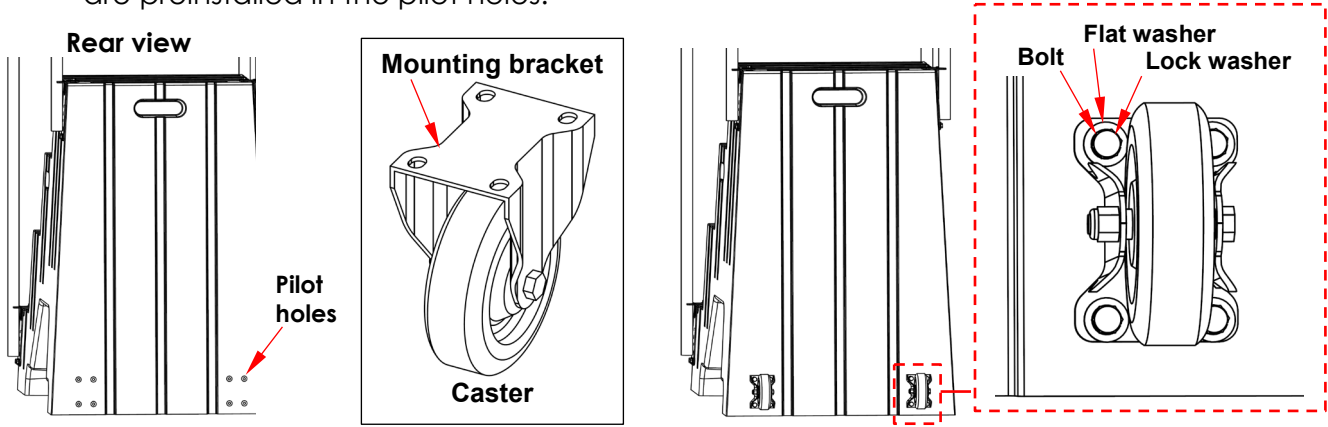

5. **Install the molded rubber feet (14-145-179)**
 NOTE: Feet are installed at the factory.
 - a. Lay the steps on the left or right side.
 - b. Locate the 8 openings that receive the feet (circled).
 - c. Press a foot into each opening. The yellow floor material of the steps should seat between the floor pad and the retaining ring.

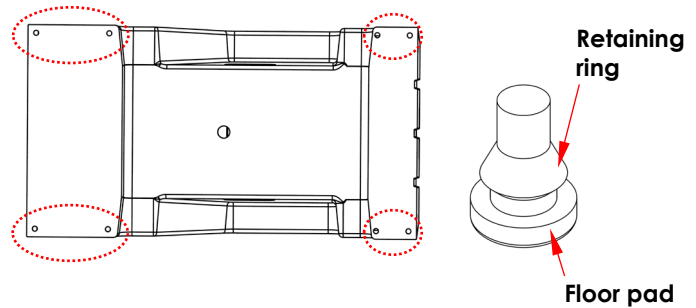

USING THE STEPS

Only use the steps on level, even ground. Make sure that all (8) molded feet make solid contact with the ground before standing on the steps.

Move the steps by grasping the handrail posts at the top of the steps. Pull the handrails towards you to tip the steps onto the casters. Push the steps to the desired location.

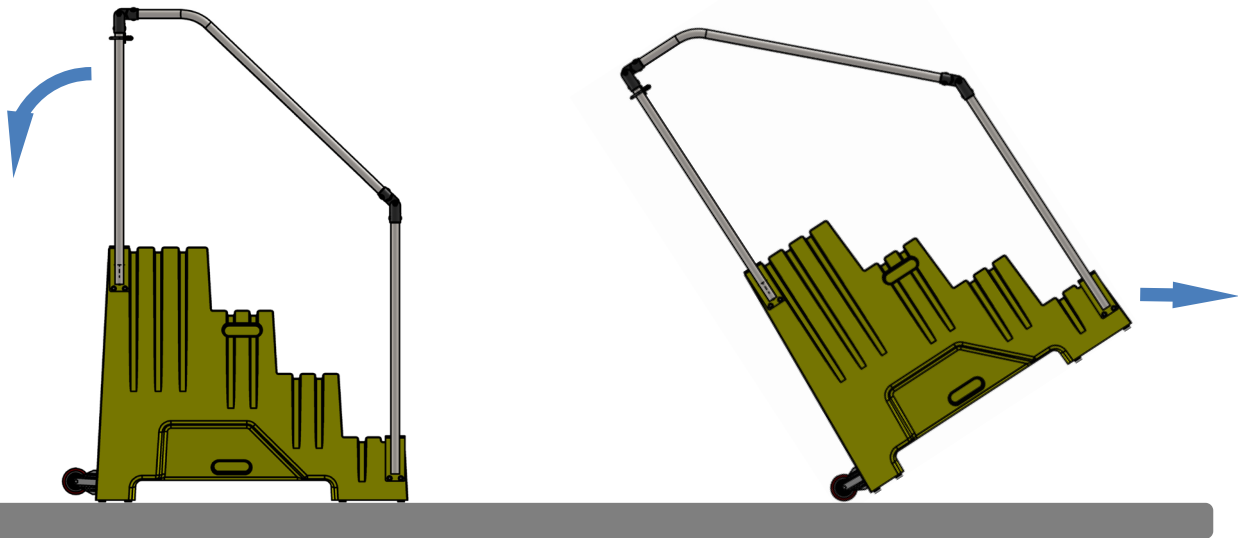

RECORD OF SATISFACTORY CONDITION (THE “RECORD”)

After the unit is assembled, make a detailed record of its condition. Include observations about all features: all surfaces and the underside, handrails, feet, anti-slip tape, fasteners (bolts, nuts, washers) and casters. Thoroughly photograph the unit from multiple angles so that all features are clearly imaged. Photograph all labels applied to the product and all information molded into the (yellow) plastic material. Collect all photographs and writings in a single file. This file is a record of the product in satisfactory condition. Compare the results of each inspection to this *RECORD* to determine if the unit is in satisfactory condition. Do not use the product unless it is in satisfactory condition.

INSPECTIONS AND MAINTENANCE

Compare inspection results to the [RECORD](#). Do not continue to use the steps unless every component is in [SATISFACTORY CONDITION](#). Cosmetic changes, like damaged handrail paint/powder coat, are not changes from satisfactory condition. However, touchup paint should be applied to all affected areas as soon as damage occurs. Contact [TECHNICAL SERVICE](#) to order replacement parts. Contact information is provided on the cover page of this manual.

Inspect the following at least once per month:

1. Step surfaces – Check all surfaces of the product for dirt or other matter, especially fluids. Clean the steps. Look for cracks, rot, flaking, and other forms of damage. Pay particular attention to the condition of the bottom edge. If the stepstool is cracked, remove it from service.
2. Handrails and fasteners – Examine both handrails & fasteners (bolts, nuts, & washers). Replace damaged/worn hardware. The handrails must be solidly fastened to the stool. If a lock nut is unfastened from its bolt, it must be replaced with a new lock nut.
3. Molded rubber feet – Examine each foot for damage and significant wear. Do not use the steps unless all 8 rubber feet are installed and in satisfactory condition. To install replacement feet, follow [ASSEMBLING THE STEPS](#) instruction 5 on page 7.
4. Casters – Inspect both casters for damage and significant wear. The casters must be solidly attached to the back of the steps.
5. Labels– Replace each label that is damaged, missing, or not easily readable.
6. Anti-slip tape strips – There should be 3 strips of anti-slip tape applied to the step surface of the first 3 steps. The top step should have 4 strips of tape. Make sure that anti-slip, abrasive material is present along the entire length and width of each strip of tape. Tape strips should not be peeling off of the steps.

LABELING DIAGRAM

Label content and location are subject to change so your product might not be labeled exactly as shown. Compare this diagram to the [RECORD](#). If differences exist between the diagram and the [RECORD](#), contact [TECHNICAL SERVICE](#). Replace all labels that are damaged, missing, or not easily readable (e.g. faded). To order replacement labels, contact the technical service and parts department online at http://www.vestilmfg.com/parts_info.htm or by calling (260) 665-7586 and asking the operator to connect you to the [TECHNICAL SERVICE & PARTS DEPARTMENT](#).

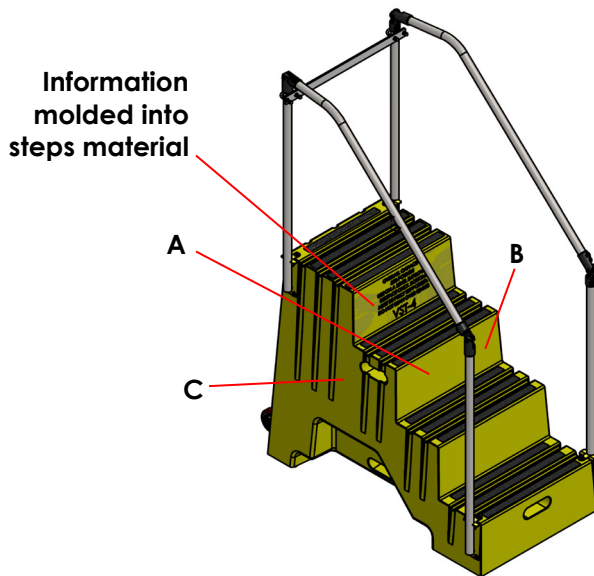

A: Label 1153

MODEL / MODÉLO / MODÈLE _____
WEIGHT / PESO / MASS _____
CAPACITY / CAPACIDAD / CAPACITÉ _____
SERIAL / SERIE / SÉRIE _____
UNITS: 2.2 lb. = 1kg 1" (or 1in.) = 2.54cm 1153

B: Label 740

⚠ WARNING	⚠ ADVERTENCIA	⚠ AVERTISSEMENT
<ul style="list-style-type: none"> • Do not use near live electric lines • Do not climb rails or lean over rails • Do not use if damaged or worn • Use ladder on level, smooth surfaces only 	<ul style="list-style-type: none"> • No use cerca de líneas eléctricas • No se suba o se asome en la barandilla • No use si esta danado o gastado • Use la escalera en superficies a nivel y lisas 	<ul style="list-style-type: none"> • Ne pas utiliser près des lignes électriques sous tension • Ne pas grimper sur ou vous pencher des rails • Ne pas utiliser si endommagée ou usagée • Utiliser l'échelle seulement sur des surfaces plates et lisses

C: Label 731

⚠ CAUTION

TIPPING HAZARD
CENTER BODY
BETWEEN SIDERAILS.
DO NOT OVER-REACH
IN ANY DIRECTION.

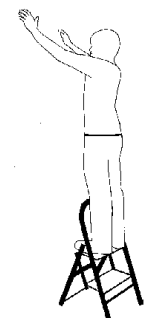

731

**SET ALL FOUR FEET
OF LADDER ON
FIRM LEVEL SURFACE.**



LIMITED WARRANTY

Vestil Manufacturing Corporation ("Vestil") warrants this product to be free of defects in material and workmanship during the warranty period. Our warranty obligation is to provide a replacement for a defective, original part covered by the warranty after we receive a proper request from the Warrantee (you) for warranty service.

Who may request service?

Only a warrantee may request service. You are a warrantee if you purchased the product from Vestil or from an authorized distributor AND Vestil has been fully paid.

Definition of "original part"?

An original part is a part used to make the product as shipped to the Warrantee.

What is a "proper request"?

A request for warranty service is proper if Vestil receives: 1) a photocopy of the Customer Invoice that displays the shipping date; AND 2) a written request for warranty service including your name and phone number. Send requests by one of the following methods:

<u>US Mail</u>	<u>Fax</u>	<u>Email</u>
Vestil Manufacturing Corporation 2999 North Wayne Street, PO Box 507 Angola, IN 46703	(260) 665-1339 <u>Phone</u> (260) 665-7586 in subject field.	info@vestil.com Enter "Warranty service request"

In the written request, list the parts believed to be defective and include the address where replacements should be delivered. After Vestil receives your request for warranty service, an authorized representative will contact you to determine whether your claim is covered by the warranty. Before providing warranty service, Vestil will require you to send the entire product, or just the defective part (or parts), to its facility in Angola, IN.

What is covered under the warranty?

The warranty covers defects in the following original, dynamic parts: motors, hydraulic pumps, motor controllers, and cylinders. It also covers defects in original parts that wear under normal usage conditions ("wearing parts"), such as bearings, hoses, wheels, seals, brushes, and batteries.

How long is the warranty period?

The warranty period for original dynamic components is 30 days. For wearing parts, the warranty period is 30 days. Both warranty periods begin on the date Vestil ships the product to the Warrantee. If the product was purchased from an authorized distributor, the periods begin when the distributor ships the product. Vestil may, at its sole discretion, extend a warranty period for products shipped from authorized distributors by up to 30 days to account for shipping time.

If a defective part is covered by the warranty, what will Vestil do to correct the problem?

Vestil will provide an appropriate replacement for any covered part. An authorized representative of Vestil will contact you to discuss your claim.

What is not covered by the warranty?

The Warrantee (you) are responsible for paying labor costs and freight costs to return the product to Vestil for warranty service.

Events that automatically void this Limited Warranty.

- Misuse;
- Negligent assembly, installation, operation or repair;
- Installation/use in corrosive environments;
- Inadequate or improper maintenance;
- Damage sustained during shipping;
- Collisions or other accidents that damage the product;
- Unauthorized modifications: Do not modify the product IN ANY WAY without first receiving written authorization from Vestil.

Do any other warranties apply to the product?

Vestil Manufacturing Corp. makes no other express warranties. All implied warranties are disclaimed to the extent allowed by law. Any implied warranty not disclaimed is limited in scope to the terms of this Limited Warranty. Vestil makes no warranty or representation that this product complies with any state or local design, performance, or safety code or standard. Noncompliance with any such code or standard is not a defect in material or workmanship.