

# Add-A-Level™ Assembly Instructions

The guide on the following page(s) was provided by the supplier. New Pig Corporation assumes no responsibility, obligation, or liability in conjunction with the use or misuse of the information.



**New Pig**

One Pork Avenue  
Tipton, PA 16684-0304

**newpig.com**

North America: **1-800-468-4647**

Europe: **+31 (0)76 596 92 50**

China: **+86-21-400 921 5178**

UK: **0800 919 900**

Outside North America: **+1-814-684-0101**

PIG, PIG logo are registered trademarks in USA and other countries. See [tm.newpig.com](http://tm.newpig.com)

365902

## Base



MTL1299 – 16" W X 36" L

MTL1299 – 24" W X 36" L

MTL1299 – 36" W X 36" L

MTL1299 – 24" W X 48" L

MTL1299 – 16" W X 66" L

MTL1299 – 24" W X 66" L

MTL1299 – 36" W X 66" L

MTL1299 – 16" W X 96" L

MTL1299 – 24" W X 96" L

MTL1299 – 36" W X 96" L

## Stacker

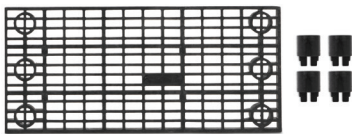

MTL1411 – 16" W X 36" L

MTL1411 – 24" W X 36" L

MTL1411 – 36" W X 36" L

MTL1411 – 24" W X 48" L

MTL1411 – 16" W X 66" L

MTL1411 – 24" W X 66" L

MTL1411 – 36" W X 66" L

MTL1411 – 16" W X 96" L

MTL1411 – 24" W X 96" L

MTL1411 – 36" W X 96" L

## Connector Clip



MTL1421

For ease of assembly spray all sockets with Simple Green or Windex

## Add-A-Level™ Raised Work Platform Base

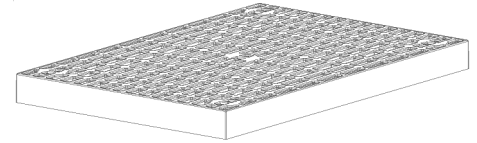
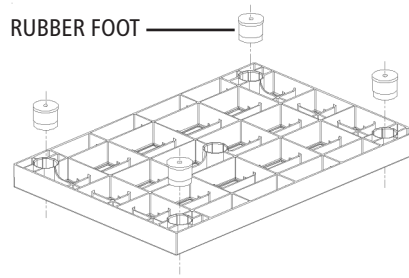

### Step 1

Invert platform and insert rubber feet.

**Note:** Item may ship pre-assembled.

## Add-A-Level™ Raised Work Platform Stacker

**Note:** Larger platforms should be disassembled before moving. Proper lubrication of the sockets during assembly dramatically helps during disassembly. Separate panels equally by pulling apart the panels in small increments at the stackers until they are free.

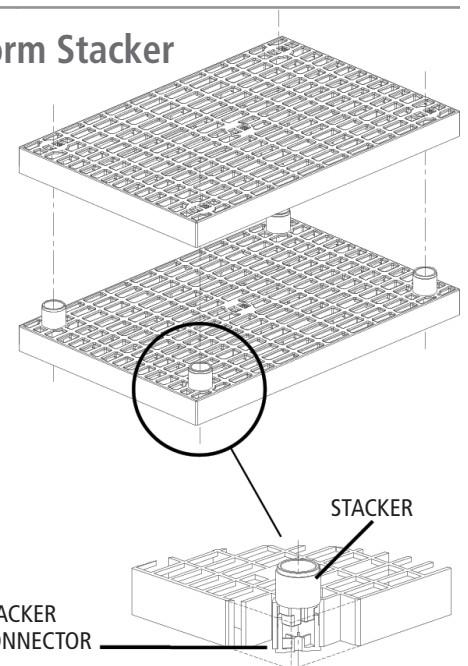
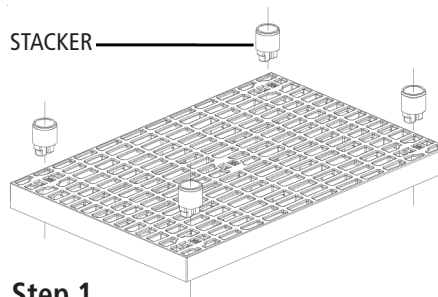

### Step 1

Set completed base unit upright and insert stackers in sockets as shown.

### Step 2

Align upper-level platform and lower-level stackers. Push upper platform all the way down over stackers. Repeat steps for multi-level configurations.

## Add-A-Level™ w/ Platform Connector Clip

**Note:** Connector Clips are used when connecting Add-A-Level Work Platforms horizontally.

### Step 1

Position clip on outside edge and inside rib as shown. Use at least two clips per panel joint.

### Step 2

Align Platform A and set down on clip using the outside edge and inside rib.

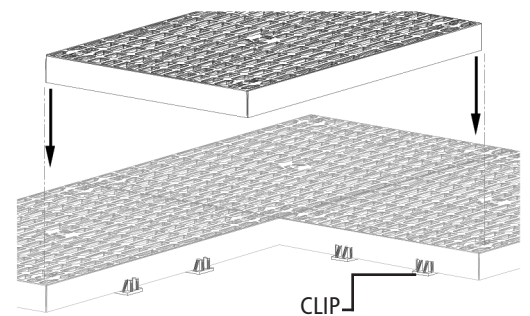

## Matting



MTL1295 – 16" W X 36" L

MTL1295 – 24" W X 36" L

MTL1295 – 36" W X 36" L

MTL1295 – 24" W X 48" L

MTL1295 – 24" W X 66" L

MTL1295 – 36" W X 66" L

MTL1295 – 24" W X 96" L

MTL1295 – 36" W X 96" L

## Add-A-Level™ Raised Work Platform Matting

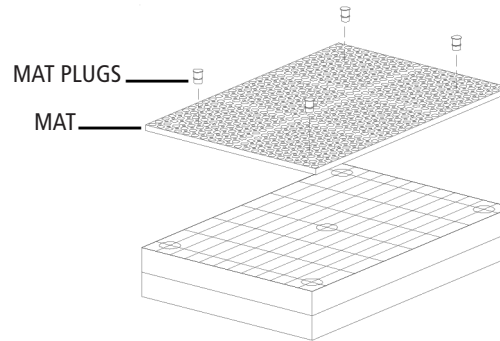

### Mat

Align mat with platform and insert mat plugs through the holes in the mat approximately **4 holes by 4 holes** from the corners. Push plugs all the way down as shown, until the plugs are flush with the mat surface and locked into the grid of panel.