

Proline Packaging Worktable 60” Plastic Laminate Work Surface

The guide on the following page(s) was provided by the supplier. New Pig Corporation assumes no responsibility, obligation, or liability in conjunction with the use or misuse of the information.



New Pig

One Pork Avenue
Tipton, PA 16684-0304

newpig.com

North America: **1-800-468-4647**

Europe: **+31 (0)76 596 92 50**

China: **+86-21-400 921 5178**

UK: **0800 919 900**

Outside North America: **+1-814-684-0101**

PIG, PIG logo are registered trademarks in USA and other countries. See tm.newpig.com

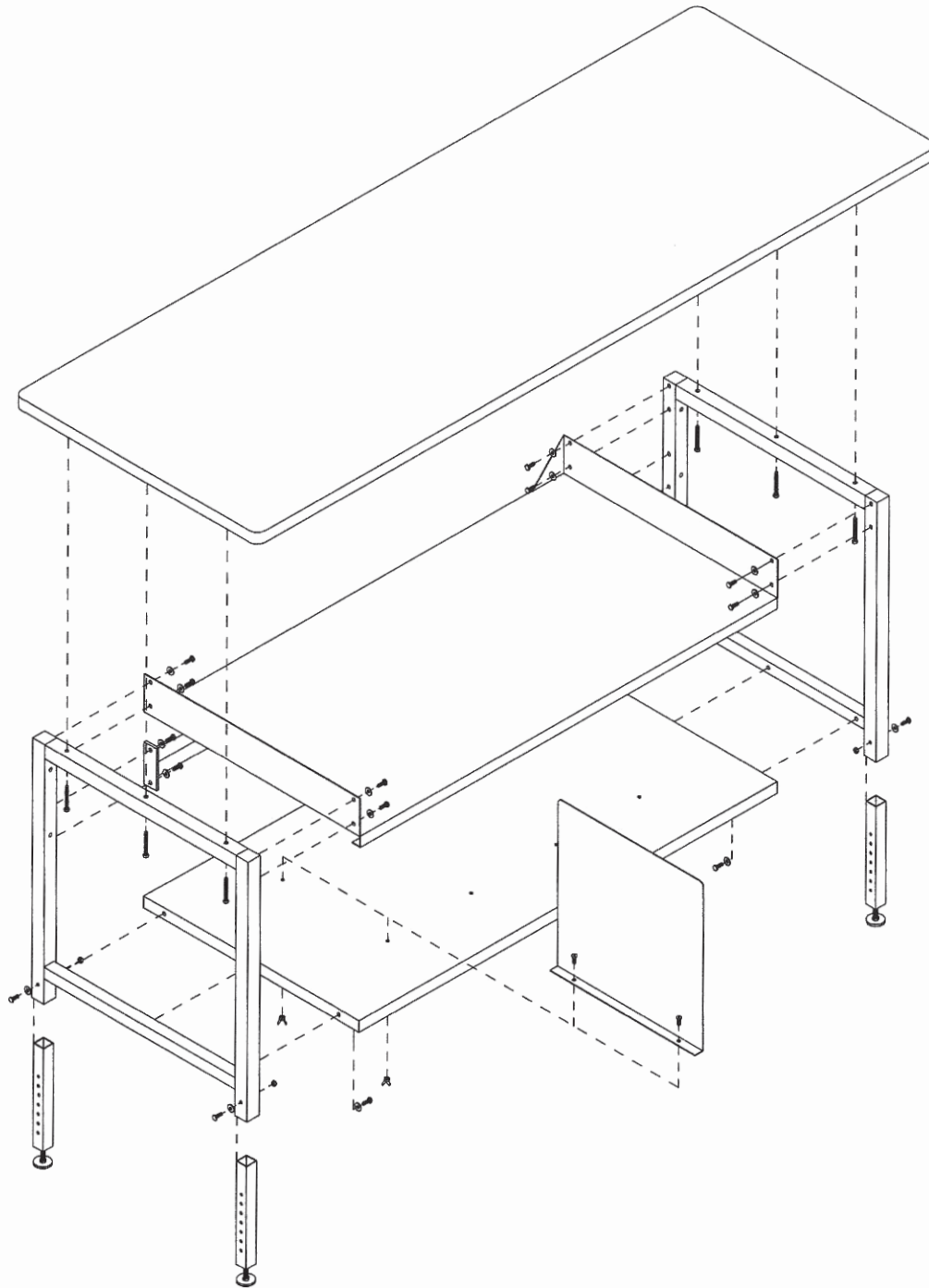

- 1) ASSEMBLE BASE FRAME USING 1/4" - 20 X 3/4" HEX HEAD BOLTS AND 1/4" WASHERS (18 PLACES)
- 2) ASSEMBLE LEG EXTENDERS USING 1/4" - 20 X 2" HEX HEAD BOLTS, FLAT WASHERS AND ELASTIC LOCK NUTS
- 3) MOUNT DIVIDERS USING 1/4" X 3/8" TRUSS HEAD BOLTS AND WING NUTS
- 4) MOUNT TOP FLUSH TO BACK OF BENCH WITH EQUAL OVERHANG ON BOTH SIDES USING #12 X 2 PHILLIPS PAN HEAD SHEET METAL SCREWS

NOTE: SHELVING AND DIVIDERS ARE OPTIONAL

PRO-LINE
PACK STATION BASE
ASSEMBLY INSTRUCTIONS
DRAWING #A7170

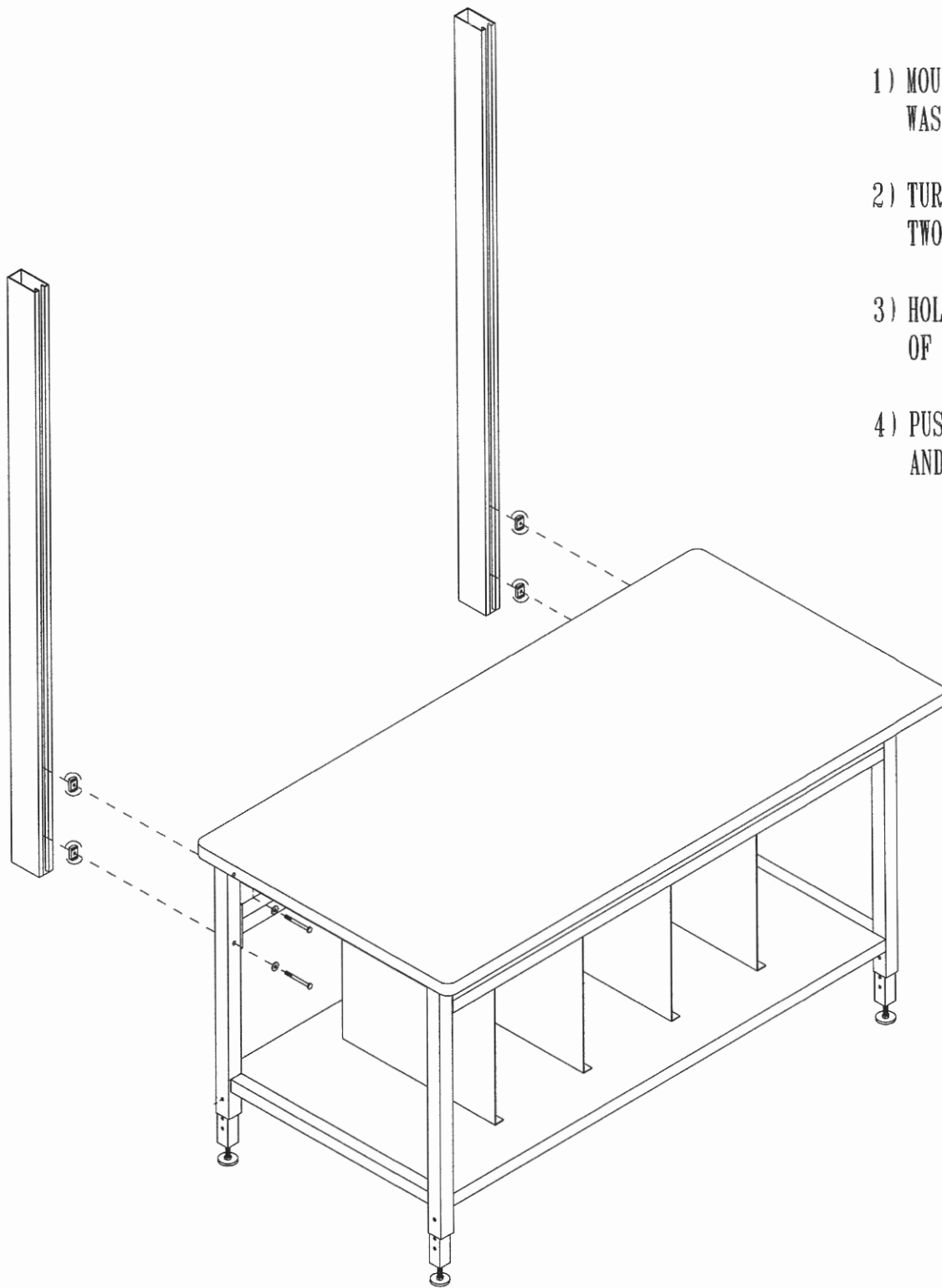

- 1) MOUNT 1/4" X 2 1/2" HEX HEAD BOLTS AND WASHERS THROUGH REAR LEGS AS SHOWN
- 2) TURN 1/4" STRUT NUTS ON APPROXIMATELY TWO (2) THREADS
- 3) HOLD HEAVY DUTY UPRIGHTS AGAINST BACK OF REAR LEGS
- 4) PUSH BOLT ASSEMBLY INTO UPRIGHTS AND TURN CLOCKWISE TO TIGHTEN

PRO-LINE
PACK STATION UPRIGHT ASSEMBLY
INSTRUCTIONS
DRAWING #A7241

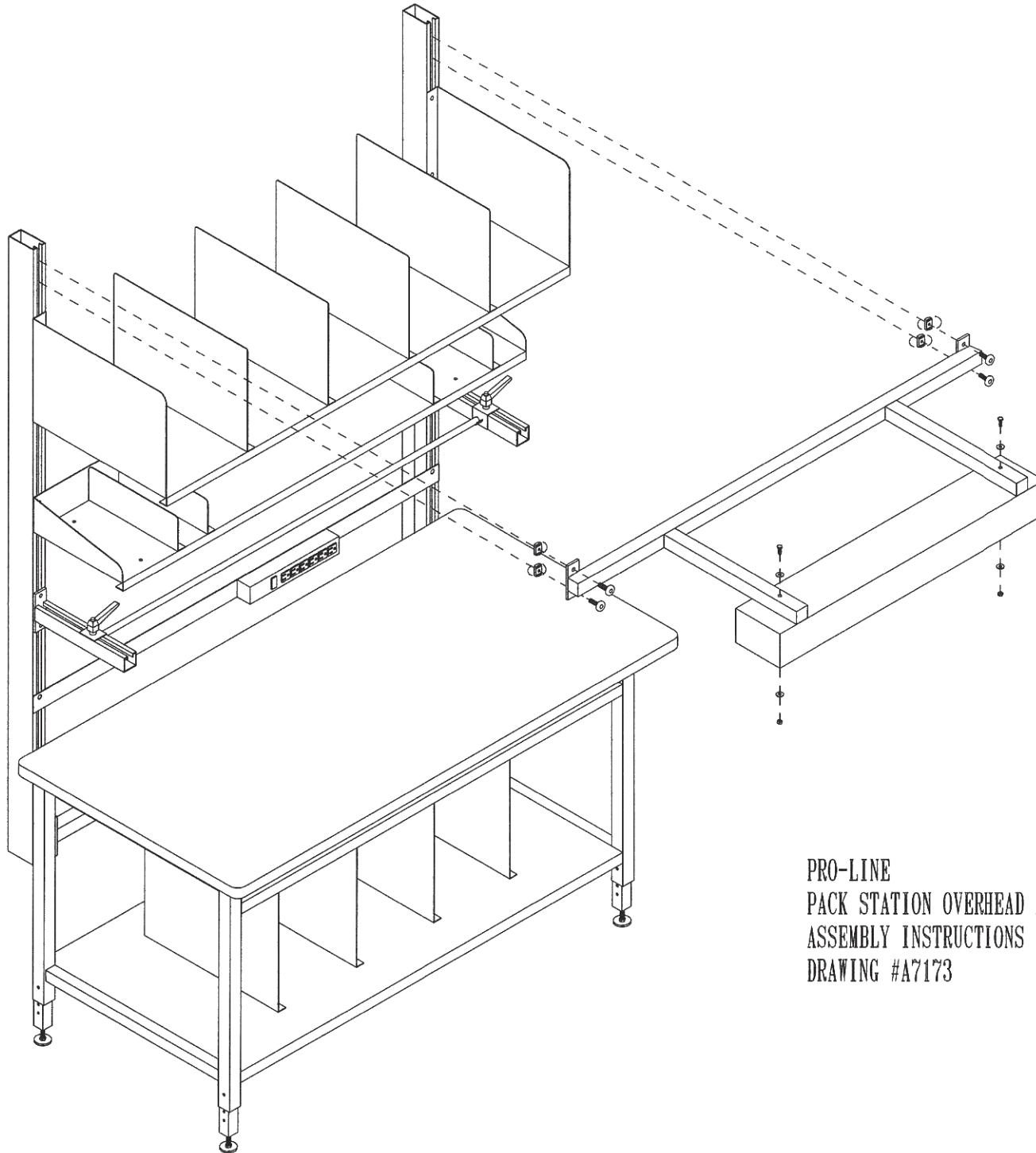

1) MOUNT LIGHT FRAME TO UPRIGHTS
USING 3/8" X 1" ALLEN CAP SCREWS
AND 3/8" STRUT NUTS

2) MOUNT LIGHT FIXTURE TO LIGHT
FRAME USING 1/4" - 20 X 2"
HEX HEAD BOLTS 1/4" FLAT
WASHERS AND 1/4" KEPNUTS

RECOMMENDED BULBS

36" FIXTURES	F30 T8
	F25 T8

PRO-LINE
PACK STATION OVERHEAD LIGHT
ASSEMBLY INSTRUCTIONS
DRAWING #A7173

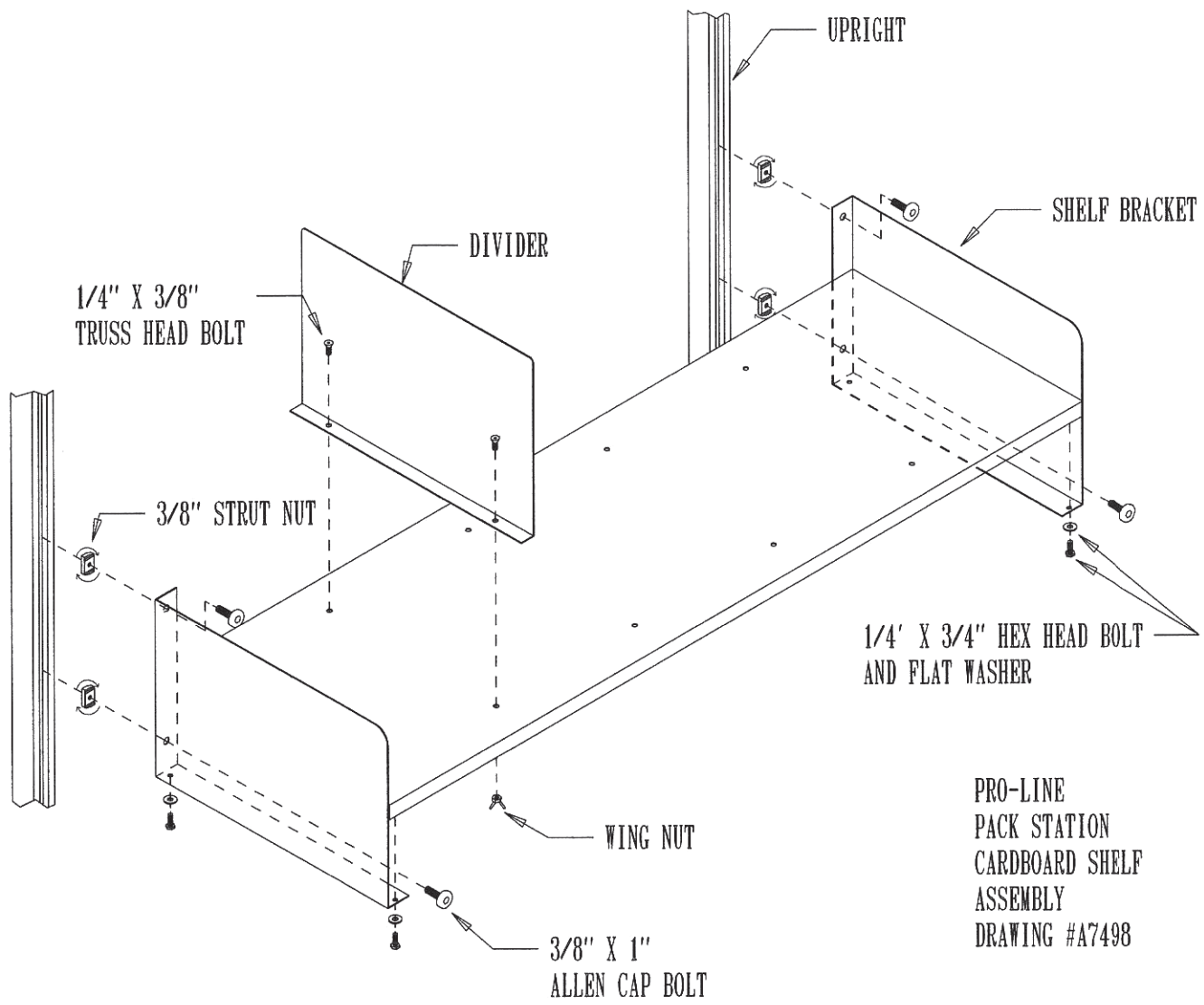

- 1) ASSEMBLE THE STEEL SHELF TO THE SHELF BRACKETS AS SHOWN USING 1/4" X 3/4" HEX HEAD BOLTS AND FLAT WASHERS.
- 2) LOOSELY ASSEMBLE THE 3/8" X 1" ALLEN CAP BOLTS AND 3/8" STRUT NUTS TO THE SHELF BRACKETS, SPIN THE STRUT NUTS ON APPROX. 2 TO 3 REVOLUTIONS. NOTE BE CERTAIN THE "TEETH" ON THE STRUT NUTS ARE FACING THE SHELF BRACKET.
- 3) AT THE DESIRED HEIGHT PUSH THE STRUT NUT ASSEMBLY INTO THE UPRIGHT CHANNEL AND TURN THE STRUT NUT ASSEMBLY CLOCKWISE MAKING SURE THE "TEETH" ON THE STRUT NUT ARE AGAINST THE "RIBS" LOCATED INSIDE THE UPRIGHT AND TIGHTEN.
- 4) MOUNT DIVIDERS TO THE SHELVES USING 1/4" X 3/8" TRUSS HEAD BOLTS AND WING NUTS

PRO-LINE
 PACK STATION
 CARDBOARD SHELF
 ASSEMBLY
 DRAWING #A7498

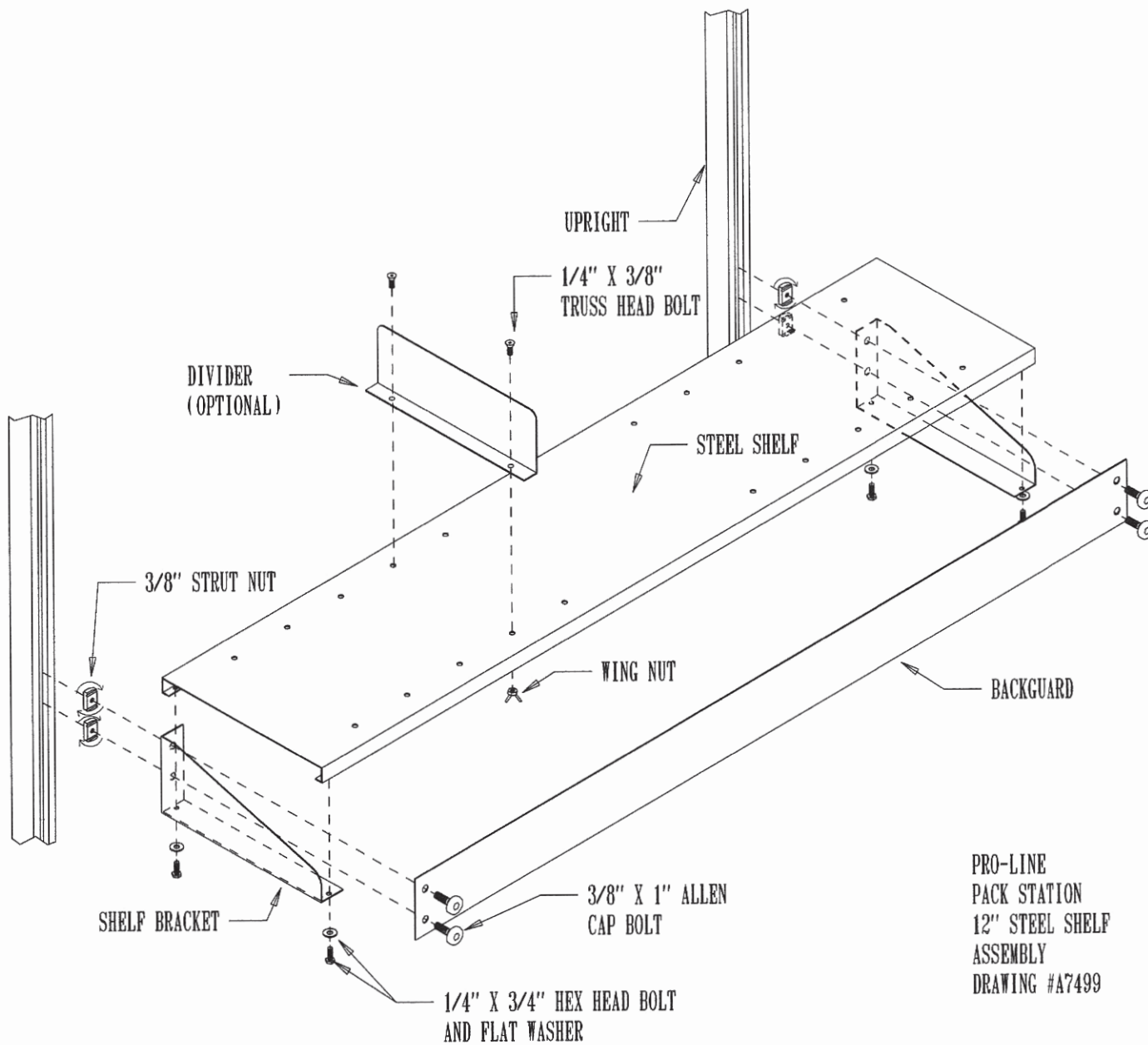

PRO-LINE
 PACK STATION
 12" STEEL SHELF
 ASSEMBLY
 DRAWING #A7499

- 1) ASSEMBLE THE STEEL SHELF TO THE SHELF BRACKETS AS SHOWN USING 1/4" X 3/4" HEX HEAD BOLTS AND FLAT WASHERS.
- 2) PLACE THE BACKGUARD AGAINST THE SHELF BRACKETS AND LOOSELY ASSEMBLE THE 3/8" X 1" ALLEN CAP BOLTS AND 3/8" STRUT NUTS TO THE SHELF BRACKETS, SPIN THE STRUT NUTS ON APPROX. 2 TO 3 REVOLUTIONS. NOTE BE CERTAIN THE "TEETH" ON THE STRUT NUTS ARE FACING THE SHELF BRACKET.
- 3) AT THE DESIRED HEIGHT PUSH THE STRUT NUT ASSEMBLY INTO THE UPRIGHT CHANNEL AND TURN THE STRUT NUT ASSEMBLY CLOCKWISE MAKING SURE THE "TEETH" ON THE STRUT NUT ARE AGAINST THE "RIBS" LOCATED INSIDE THE UPRIGHT AND TIGHTEN.
- 4) MOUNT DIVIDERS (IF PURCHASED) TO THE SHELVES USING 1/4" X 3/8" TRUSS HEAD BOLTS AND WING NUTS

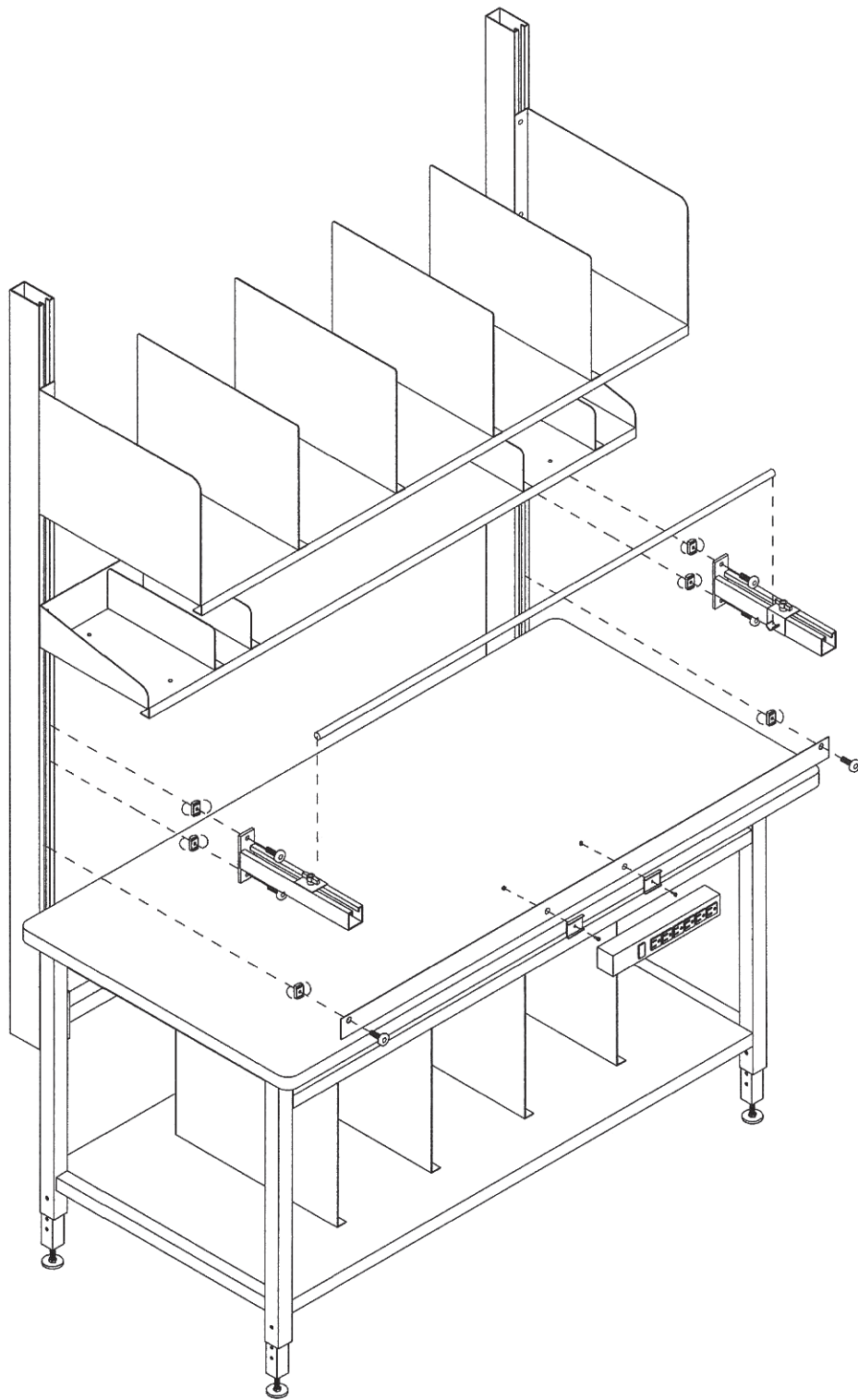

- 1) MOUNT PAPER SPOOL HOLDER AND ESMR AT DESIRED HEIGHT USING 3/8" X 1" ALLEN CAP SCREWS AND STRUT NUTS
- 2) SECURE THE ELECTRICAL STRIP SPRING CLIPS TO THE ESMR USING 6/32" X 3/8" SLOTTED HEAD BOLTS AND 6/32" HEX NUTS.
- 3) SNAP ELECTRICAL STRIP INTO SPRING CLIPS

PRO-LINE
PACK STATION ESMR AND ES/
SPOOL HOLDER ASSEMBLY
INSTRUCTIONS
DRAWING # A7172-OLD