

Vestil Bulk Bag Rack

The guide on the following page(s) was provided by the supplier. New Pig Corporation assumes no responsibility, obligation, or liability in conjunction with the use or misuse of the information.



New Pig

One Pork Avenue
Tipton, PA 16684-0304

newpig.com

North America: **1-800-468-4647**

Europe: **+31 (0)76 596 92 50**

China: **+86-21-400 921 5178**

UK: **0800 919 900**

Outside North America: **+1-814-684-0101**

PIG, PIG logo are registered trademarks in USA and other countries. See tm.newpig.com

364941



Vestil Manufacturing Corp.

2999 North Wayne Street, P.O. Box 507, Angola, IN 46703

Telephone: (260) 665-7586 -or- Toll Free (800) 348-0868

Fax: (260) 665-1339

Web: www.vestilmfg.com e-mail: info@vestil.com

BBL-RK-72 Bulk Bag Rack

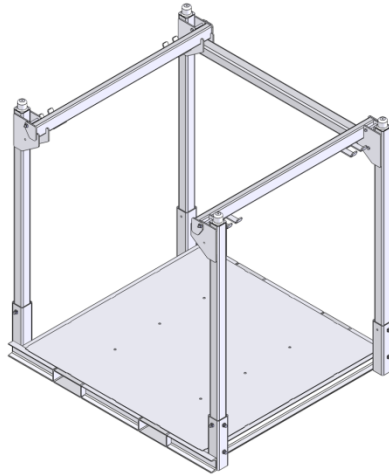

Receiving Instructions

After delivery, remove the packaging from the product. Inspect the product closely to determine whether it sustained damage during transport. If damage is discovered, record a complete description of it on the bill of lading. If the product is undamaged, discard the packaging.

NOTE: The end-user is solely responsible for confirming that product design, use, and maintenance comply with laws, regulations, codes, and mandatory standards applied where the product is used.

Technical Service & Replacement Parts

For answers to questions not addressed in these instructions and to order replacement parts, labels, and accessories, call our Technical Service and Parts Department at (260) 665-7586. The department can also be contacted online at http://www.vestilmfg.com/parts_info.htm.

Electronic copies of Instruction Manuals

Additional copies of this instruction manual may be downloaded from <https://www.vestil.com/page-manuals.php>.

Table of Contents

Page

Specifications.....	2
Exploded View and Bill of Materials.....	3
National Standards.....	3
Signal Words.....	4
Safety Instructions.....	4
Assembling the Rack.....	5
Using the Rack.....	6
Record of Satisfactory Condition.....	6
Inspections & Maintenance.....	6
Accessory Equipment.....	7
Labeling Diagram.....	7
Limited Warranty.....	8

SPECIFICATIONS (47-007-057)

Specifications for the model BBL-RK-72 bulk bag rack are provided on Vestil's website. To access the appropriate specifications document, navigate to this webpage: <https://www.vestil.com/product.php?FID=1711>. Click the "Specifications" tab. Scroll the page to the entry for the model you purchased, and click the button in the PDF column that looks like a pencil inside a box. A PDF file will open. This file is the specifications document. Print a copy of the document and keep it with your copy of this manual. The following is a copy of the specifications document.

BULK BAG LIFTER RACK - BBL-RK-72

APPROX WEIGHT: 498.21 lbs.
 DOES NOT INCLUDE WEIGHT OF POWER OR PACKAGING!

*** ANY ADDITIONS, DELETIONS, OR OMISSIONS MUST BE CORRECTED ON THIS DRAWING AS THIS DRAWING WILL BE CONSIDERED ALL INCLUSIVE ***
 ALL GRAPHICS PROVIDED ARE FOR REFERENCE ONLY. IF CERTAIN DIMENSIONS ARE CRITICAL PLEASE VERIFY THOSE DIMENSIONS WITH YOUR SALESPERSON

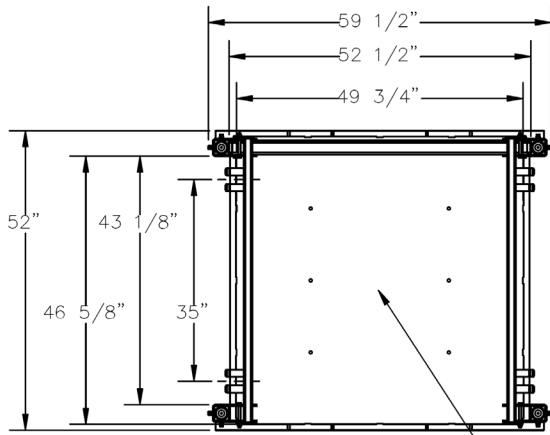

ACCOMMODATE
 PALLETS UP TO 42" L x 48" W

STANDARD FEATURES

- MODEL NUMBER IS: BBL-RK-72
- CAPACITY IS: 1,000 LBS
- OVERALL LENGTH IS: 52"
- USABLE LENGTH IS: 46 5/8"
- OVERALL WIDTH IS: 59 1/2"
- USABLE WIDTH IS: 52 1/2"
- OVERALL HEIGHT IS: 61 1/8"
- BASE HEIGHT IS: 3 1/8"
- FORK POCKETS: 7 5/8" L x 2 5/8" H ON 24" CENTERS
- BAG HOOKS ARE: 52" HIGH ON 35" x 49 3/4" CENTERS
- ACCOMMODATES PALLETS UP TO 48" WIDE
- TOUGH BAKED IN POWDER COATED BLUE FINISH

SPECIAL FEATURES

NONE

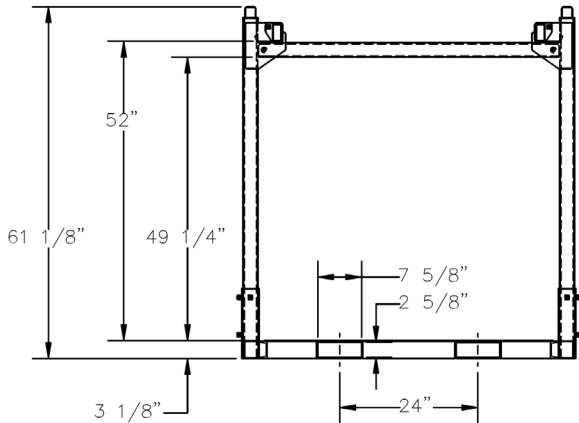

DIMENSION TOLERANCE ± 1/4"

APPROVAL	I, THE UNDERSIGNED, AGREE THAT THE PRODUCT AS REPRESENTED SATISFIES DESIGN AND DIMENSION REQUIREMENTS. I ALSO ACKNOWLEDGE MY DUTY TO CONFIRM PRODUCT AND INSTALLATION COMPLIANCE WITH ALL APPLICABLE FEDERAL, STATE AND LOCAL REGULATIONS AND STANDARDS.		
	UNITS REQUIRING APPROVAL DRAWINGS OR MODIFIED ARE NON-RETURNABLE		
	[] As drawn [] As marked		
	Signed: _____ Date: _____		
Printed Name: _____			
LEAD TIME WILL START UPON RECEIPT OF SIGNED APPROVAL DRAWING			
DISTRIBUTOR'S NAME: VESTIL MANUFACTURING		P.O.# X	
DRAWN BY: JGP	DATE: 3/31/2021	W.O.# X	
REFERENCE: X	SCALE: 1:22	SALES: X	
QUOTED LEAD TIME: X	QUOTE # X	FILE NAME: 47-007-057	

EXPLODED VIEW AND BILL OF MATERIALS (47-006-057)

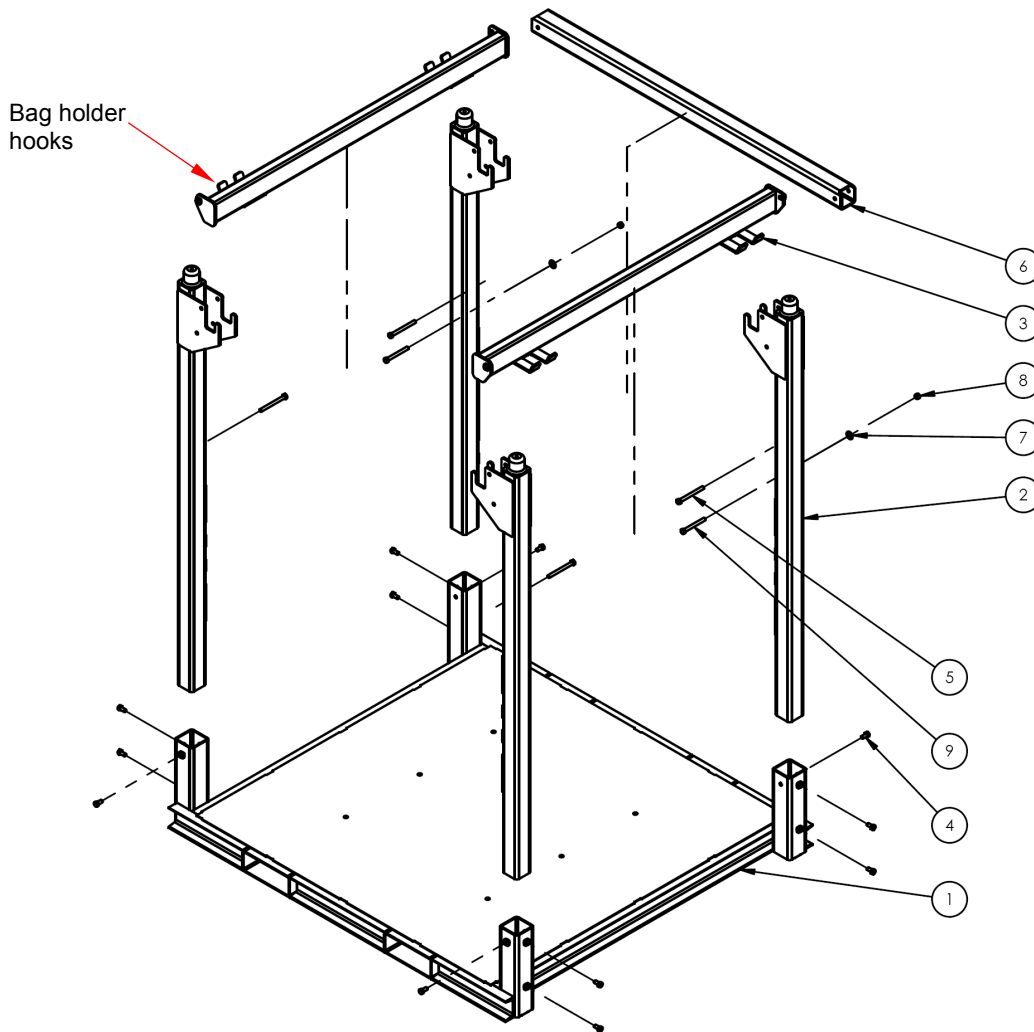



ITEM	PART NO.	DESCRIPTION	QTY.
1	47-514-032	WELDMENT, FRAME W/ PLATE	1
2	47-514-033	WELDMENT, FRAME, POST	4
3	47-514-036	WELDMENT, FRAME, BAG MOUNTING	2
4	11103	HEX BOLT, GRADE A, ZINC PLATED, 3/8-16X3/4	12
5	11119	HEX BOLT, GRADE A, ZINC FINISH, 3/8"-16 x 4"	4
6	47-014-071	FRAME, SUPPORT TUBE	1
7	33007	3/8" USS FLAT WASHER, PLAIN	2
8	36106	HEX NUT, GRADE A, ZINC PLATED, 3/8-16	2
9	11117	HEX HEAD, HHCS #2 Z PLATED, 3/8 - 16 x 3 1/2	2

NATIONAL STANDARDS

US OSHA Rule 1910.178 (29 CFR 1910.178; the "Rule") classifies this device as a front end attachment whenever it is mounted on the forks of a lift truck. The Rule incorporates American National Standard ANSI/ITSDF B56.1 (the "Standard"). The Standard is published by the Industrial Truck Standards Development Foundation on its website where it is freely downloadable at <http://www.itsdf.org/cue/b56-standards.html>. Before putting this device into service, you must acquire a copy of the Standard. Apply all relevant parts of Part II: For the User. If instructions provided in this manual conflict with the Standard, then apply the instructions in the Standard. Vestil requests that you immediately bring such conflicts to the attention of its [TECHNICAL SERVICE](#) personnel. Contact information for [TECHNICAL SERVICE](#) appears on the cover page of this manual.

SIGNAL WORDS

This manual uses SIGNAL WORDS to indicate the likelihood of personal injuries, as well as the probable seriousness of those injuries, if the product is misused in the ways described. Other signal words call attention to uses of the product likely cause property damage. The following are signal words used in this manual and their definitions.

 DANGER	Identifies a hazardous situation which, if not avoided, WILL result in DEATH or SERIOUS INJURY . Use of this signal word is limited to the most extreme situations.
 WARNING	Identifies a hazardous situation which, if not avoided, COULD result in DEATH or SERIOUS INJURY .
 CAUTION	Indicates a hazardous situation which, if not avoided, COULD result in MINOR or MODERATE injury.
NOTICE	Identifies practices likely to result in product/property damage, such as operation that might damage the product.

SAFETY INSTRUCTIONS

Vestil strives to identify foreseeable hazards associated with the use of its products. However, no manual can address every conceivable risk. The most effective way to avoid injury is to exercise sound judgment when assembling, using, inspecting, and maintaining this crane.

WARNING

Risks of serious personal injuries or death.

- **Read this manual in its entirety before assembling, using, inspecting or servicing the product.** Read the manual to refresh your understanding of use, inspection, and maintenance procedures as necessary. A copy of this manual should always be available to all persons who assemble, use, inspect and/or maintain this device.
- Review the safety messages included on labeling, and in the manuals, of devices used with this bulk bag rack: bulk bag and forklift.
- Inspect & maintain the rack as instructed in the [INSPECTIONS & MAINTENANCE](#) section on p. 6. Do not use the rack unless it is in [SATISFACTORY CONDITION](#). See [RECORD OF SATISFACTORY CONDITION, p. 4](#).
- DO NOT remove or obscure any label. Before using the rack, confirm that all labels are in place and easily readable from a reasonable distance. See [LABELING DIAGRAM](#) on p. 7.
- DO NOT allow people to ride in the bulk bag or on the rack.
- DO NOT lift more than the capacity/rated load of this rack or the bulk bag, whichever is smaller. The capacity of the rack is 1,000 pounds (454.5 kg). The capacity of Vestil's FAB-H bulk bag is 3,300 pounds (1500kg). If this rack is used to hold and move an FAB-H bag, the bag and its contents must not weight more than 1,000 pounds.
- Before mounting a bulk bag on the rack, inspect the bulk bag handles and the bag. Confirm that all parts are in good condition. DO NOT use the lifter to support or transport a bag UNLESS the handles and bag are undamaged.
- DO NOT lift or travel with a load elevated more than necessary to avoid contact with the ground. Bag contents might shift during transport so travel slowly. Avoid sudden stops to minimize load swing. Turn slowly and carefully. Make sure that the travel path is clear of persons and obstacles before transporting a bulk bag with this rack.
- Use this product consistently with both the relevant portions of the current revision of ANSI/ITSDF B56.1 and your lift truck operator training.
- DO NOT pull or drag the rack. ONLY use the rack to load and transport bulk bags.
- DO NOT leave an elevated load/rack unattended. Always land the rack before leaving it.
- DO NOT modify the rack in any way. Modifications automatically void the [LIMITED WARRANTY](#) (on p. 8) and might make the rack unsafe to use.

ASSEMBLING THE RACK

Step 1: Insert posts (47-514-033) into post receivers as shown in the diagrams (below). Secure each post with three (3) 3/8" – 16 x 3/4" hex bolts (11103). Tighten the bolts against the sides of the posts.

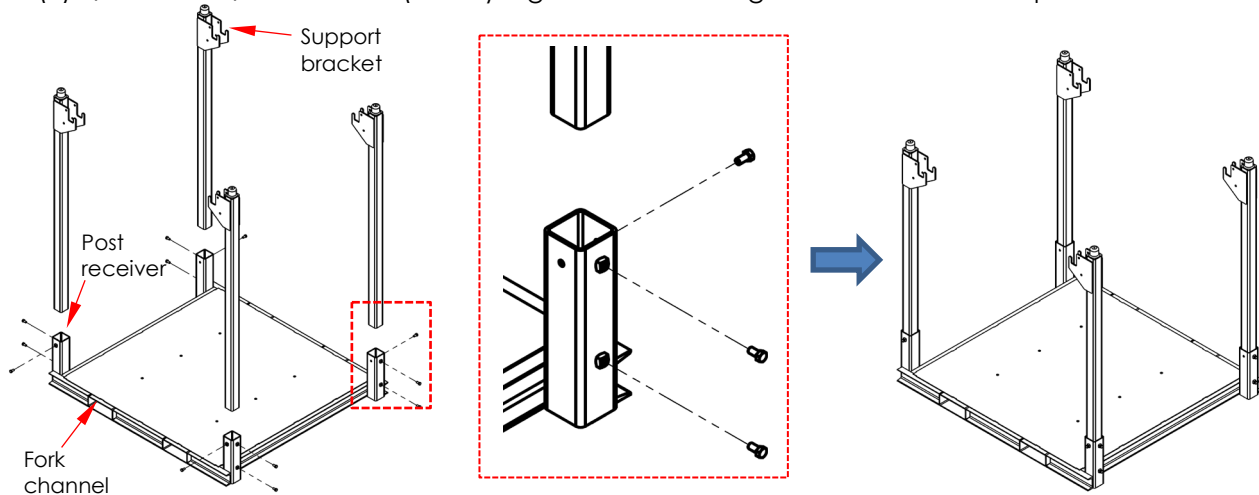

Step 2: Attach the support tube to 2 posts. Fasten the tube at each end to a post with a 3/8"-16 x 3.5" hex head bolt (11117), a 3/8" flat washer (33007), and a 3/8"-16 hex nut (36106).

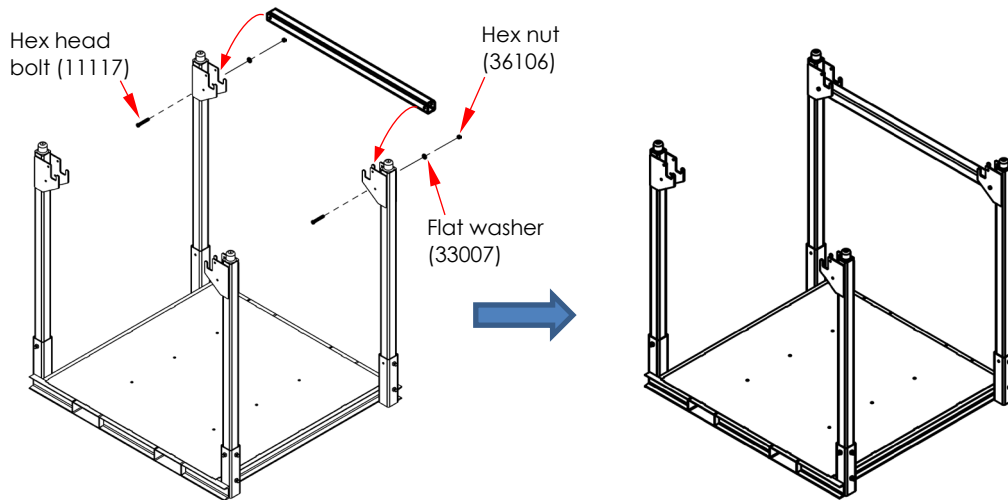

Step 3: Install the bag mounting weldments (47-514-036). Attach each end of both tubes to the support brackets with 3/8"-16 x 4" hex head bolts (11119).

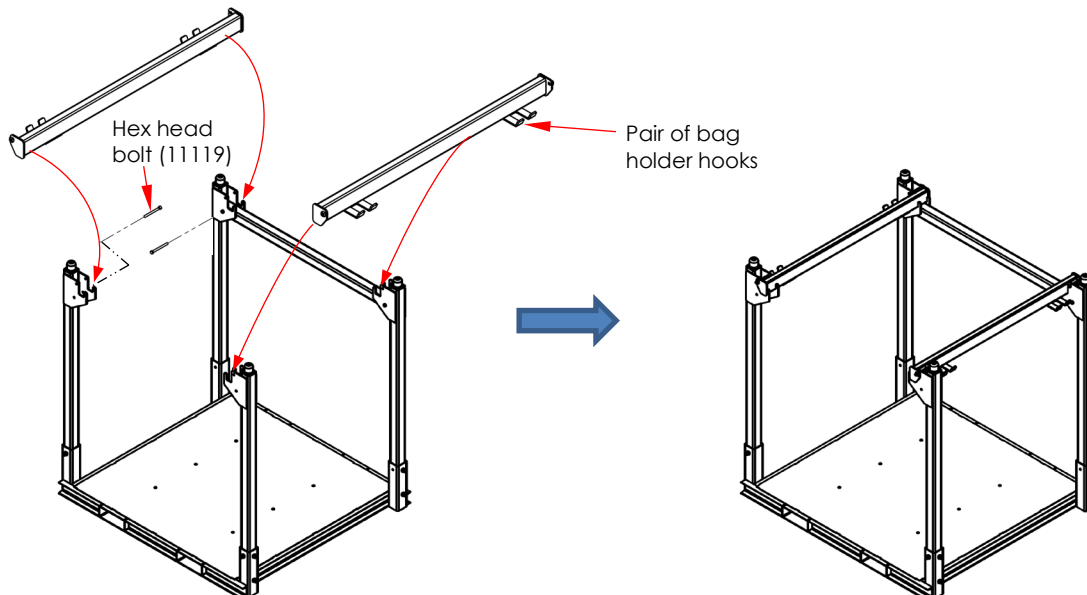

USING THE RACK

The rack can be mounted on the forks of a forklift.

NOTE: Capacity information appears in the [SPECIFICATIONS](#) section on p. 2 as well as on label #1153. See [LABELING DIAGRAM](#) on p. 7. The capacity of a properly assembled and maintained rack unit is 1,000 lb. (454.5kg). Do not apply loads to the rack that exceed the capacity of your unit. The forklift used with this rack must be able to support the combined weight of the rack, the bulk bag, and the material inside the bulk bag.

Attach a bulk bag:

Attach a fabric hopper/bulk bag to the rack. Attach each of the (4) straps of the bag to one pair of bag holder hooks. See [ASSEMBLING THE RACK, STEP 3](#), p. 5. The bulk bag is now ready to be used.

Mounting the rack on forks:

- a. Adjust the positions of the forks to match to locations of the fork channels of the rack.
- b. Insert the forks through both fork channels. Drive as far forward as possible. The fork tips should extend through the opposite ends of the channels. Raise the fork tips slightly to prevent the rack from sliding forward.
- c. Elevate the forks only as high as necessary to raise the rack off of the ground. Drive slowly and carefully. Brake very gradually. Turn slowly and carefully.

[OSHA rule 29 CFR 1910.178](#) applies to front end attachments. The rule requires that you contact the manufacturer of your fork truck (or a professional engineer). The manufacturer must determine how mounting the rack on your forklift affects the capacity, operation, and maintenance of your fork truck. The analysis can also be performed by a professional engineer. Afterwards, plates, tags, labels, etc. affixed to the truck must be updated. The truck should also be marked to identify this BBL-4 attachment and to display the approximate weight of the truck and attachment combination at maximum elevation with a laterally centered load.

RECORD OF SATISFACTORY CONDITION (THE "RECORD")

Before putting the rack into service, record its appearance. Thoroughly photograph the unit so that all features are clearly visible. Take close range photographs of the support brackets, hook pairs, post receivers, labels and tags applied to the rack as well as all fasteners. Collect the photographs in a file. The file is a record of the unit in satisfactory condition. Compare the results of each inspection to this record to determine whether the unit is in satisfactory condition. Do not use it unless it is in satisfactory condition.

INSPECTIONS & MAINTENANCE

Compare the results of each inspection to the [RECORD](#) to determine whether the unit is in satisfactory condition. DO NOT use the rack unless it is in satisfactory condition. Only use manufacturer-approved replacement parts to restore the unit to satisfactory condition. *Never make temporary repairs of damaged or missing parts.* **DON'T GUESS! If you have any questions about the condition of your unit, contact the [TECHNICAL SERVICE](#) department.** The phone number is provided on the cover page of this manual. Purely cosmetic changes, such as chipped paint, are not changes from satisfactory condition. However, unprotected steel rusts so touchup paint should be applied to all areas where the finish is damaged as soon as the damage occurs. Left unaddressed, rusting could compromise the soundness of the metal and create a safety hazard.

Inspect the listed components **at least 1 time per month:**

- 1.) Base frame: Inspect the fork channels and base frame for deformations, cracks, significant rusting/corrosion, etc.
- 2.) Posts, post receivers, and fasteners: Closely examine each item for cracks, bends, twists, elongations, thinned areas, and rusting/corrosion, or significant wear. Pay particular attention to post receivers, support brackets, and hook pairs.
- 3.) Labels & tags: Confirm that each label and/or tag is present and easily readable.

Maintain the rack by replacing damaged hardware, applying touchup paint to areas where the surface coating is damaged, and replacing components that are found not to be in satisfactory condition.

ACCESSORY EQUIPMENT

A selection of equipment is available for use with BBL-RK-72 bulk bag racks:

- **BBL-OC-4:** Fork-mountable bulk bag lifter with an open center. The lifter provides solutions for both loading and transporting bulk bags.
- **BBL-OC-RK:** Steel arms that fasten to an open center bulk bag lifter (BBL-OC-4). These arms allow an open center bulk bag lifter (BBL-OC-4) to be removably mounted on the upper supports of a BBL-RK-72 support rack. Hang a bulk bag from the lifter. The filled bulk bag can be moved while the rack remains in place simply by inserting the forks of your lift truck through the fork channels of the lifter and lifting it free of the rack.
- **BBL-B001:** Complete open center bulk bag kit. The kit includes a bulk bag lifter (BBL-OC-4), 4 lifter mounting arms (BBL-OC-RK), and a bulk bag rack (BBL-RK-72). This kit provides the user with an optimally versatile bulk storage system.

LABELING DIAGRAM

Label content and location are subject to change so your product might not be labeled exactly as shown. Compare the diagram below to your [RECORD OF SATISFACTORY CONDITION](#). If differences between actual labeling and this diagram exist, contact [TECHNICAL SERVICE](#). Replace all labels that are damaged, missing, or not easily readable (e.g. faded). To order replacement labels, or to inquire whether your unit is properly labeled, contact the [TECHNICAL SERVICE AND PARTS DEPARTMENT](#) online at http://www.vestilmfg.com/parts_info.htm or by calling (260) 665-7586 and asking for the Parts Department.

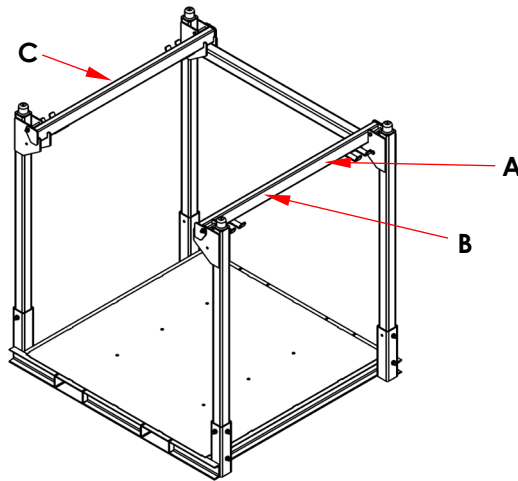

A: Label 1153

MODEL / MODÉLO / MODÈLE _____
WEIGHT / PESO / MASS _____
CAPACITY / CAPACIDAD / CAPACITÉ _____
SERIAL / SERIE / SÉRIE _____
UNITS: 2.2 lb. = 1kg 1" (or 1in.) = 2.54cm 1153

B: Label 1049

▲ WARNING
<p>Improper use of this fork attachment might result in death or serious injury.</p> <ul style="list-style-type: none"> • Using this front end attachment affects lift truck center of gravity. • Before using this fork attachment, US Federal regulation 29 CFR 1910.178 requires you to contact the manufacturer of your lift truck and request: <ol style="list-style-type: none"> 1. Written approval [29 CFR 1910.178(a)(4)] 2. Markings for (fork) lift truck that: <ul style="list-style-type: none"> - Identify the attachment; - Give approximate weight of truck and attachment at maximum elevation with laterally-centered load. [29 CFR 1910.178(a)(5)]. • DO NOT use UNTIL lift truck is marked with corrected capacity tags. • CAPACITY OF TRUCK & ATTACHMENT COMBINATION MIGHT BE LESS THAN CAPACITY OF ATTACHMENT. CONSULT TRUCK CAPACITY TAG/LABEL.
1049 rev 1120

C: Label 658

▲ WARNING	▲ ADVERTENCIA	▲ AVERTISSEMENT
Do not operate or move with unstable loads DO NOT LOAD beyond rated capacity DISTRIBUTE LOAD EVENLY DO NOT sit or ride	No use a mueva con cargas inestables No cargue mas de la capacidad tasada DISTRIBUYA LA CARGA A NIVEL NO SE SIENTE o vaya en el carro	Ne pas utiliser avec une charge instable NE PAS CHARGER au-delà du débit nominale DISTRIBUER la charge régulièrement NE PAS VOUS ASSEOIR OU VOUS PROMENER sur le chariot
658 rev 0808		



LIMITED WARRANTY

Vestil Manufacturing Corporation ("Vestil") warrants this product to be free of defects in material and workmanship during the warranty period. Our warranty obligation is to provide a replacement for a defective, original part covered by the warranty after we receive a proper request from the Warrantee (you) for warranty service.

Who may request service?

Only a warrantee may request service. You are a warrantee if you purchased the product from Vestil or from an authorized distributor AND Vestil has been fully paid.

Definition of "original part"?

An original part is a part used to make the product as shipped to the Warrantee.

What is a "proper request"?

A request for warranty service is proper if Vestil receives: 1) a photocopy of the Customer Invoice that displays the shipping date; AND 2) a written request for warranty service including your name and phone number. Send requests by one of the following methods:

<u>US Mail</u>	<u>Fax</u>	<u>Email</u>
Vestil Manufacturing Corporation 2999 North Wayne Street, PO Box 507 Angola, IN 46703	(260) 665-1339 <u>Phone</u> (260) 665-7586	info@vestil.com Enter "Warranty service request" in subject field.

In the written request, list the parts believed to be defective and include the address where replacements should be delivered. After Vestil receives your request for warranty service, an authorized representative will contact you to determine whether your claim is covered by the warranty. Before providing warranty service, Vestil will require you to send the entire product, or just the defective part (or parts), to its facility in Angola, IN.

What is covered under the warranty?

The warranty covers defects in the following original, dynamic parts: motors, hydraulic pumps, motor controllers, and cylinders. It also covers defects in original parts that wear under normal usage conditions ("wearing parts"), such as bearings, hoses, wheels, seals, brushes, and batteries.

How long is the warranty period?

The warranty period for original dynamic components is 1 year. For wearing parts, the warranty period is 90 days. Both warranty periods begin on the date Vestil ships the product to the Warrantee. If the product was purchased from an authorized distributor, the periods begin when the distributor ships the product. Vestil may, at its sole discretion, extend a warranty period for products shipped from authorized distributors by up to 30 days to account for shipping time.

If a defective part is covered by the warranty, what will Vestil do to correct the problem?

Vestil will provide an appropriate replacement for any covered part. An authorized representative of Vestil will contact you to discuss your claim.

What is not covered by the warranty?

The Warrantee (you) is responsible for paying labor costs and freight costs to return the product to Vestil for warranty service.

Events that automatically void this Limited Warranty.

- Misuse;
- Negligent assembly, installation, operation or repair;
- Installation/use in corrosive environments;
- Inadequate or improper maintenance;
- Damage sustained during shipping;
- Collisions or other accidents that damage the product;
- Unauthorized modifications: Do not modify the product IN ANY WAY without first receiving written authorization from Vestil.

Do any other warranties apply to the product?

Vestil Manufacturing Corp. makes no other express warranties. All implied warranties are disclaimed to the extent allowed by law. Any implied warranty not disclaimed is limited in scope to the terms of this Limited Warranty. Vestil makes no warranty or representation that this product complies with any state or local design, performance, or safety code or standard. Noncompliance with any such code or standard is not a defect in material or workmanship.