

Vestil Bulk Bag Lifter Rack Arms

The guide on the following page(s) was provided by the supplier. New Pig Corporation assumes no responsibility, obligation, or liability in conjunction with the use or misuse of the information.



New Pig

One Pork Avenue
Tipton, PA 16684-0304

newpig.com

North America: **1-800-468-4647**

Europe: **+31 (0)76 596 92 50**

China: **+86-21-400 921 5178**

PIG, PIG logo are registered trademarks in USA and other countries. See tm.newpig.com

UK: **0800 919 900**

Outside North America: **+1-814-684-0101**



Vestil Manufacturing Corp.

2999 North Wayne Street, P.O. Box 507, Angola, IN 46703

Telephone: (260) 665-7586 OR Toll Free (800) 348-0868

Fax: (260) 665-1339

Web: www.vestilmfg.com e-mail: info@vestil.com

BBL-OC-RK-A Rack Arms for BBL-OC-4



Receiving Instructions

After delivery, remove the packaging from the product. Inspect the product closely to determine whether it sustained damage during transport. If damage is discovered, record a complete description of it on the bill of lading. If the product is undamaged, discard the packaging.

NOTE: The end-user is solely responsible for confirming that product design, use, and maintenance comply with laws, regulations, codes, and mandatory standards applied where the product is used.

Technical Service & Replacement Parts

For answers to questions not addressed in these instructions and to order replacement parts, labels, and accessories, call our Technical Service and Parts Department at (260) 665-7586. The department can also be contacted online at http://www.vestilmfg.com/parts_info.htm.

Electronic copies of Instruction Manuals

Additional copies of this instruction manual may be downloaded from <https://www.vestil.com/page-manuals.php>.

Table of Contents

Page

Specifications.....	2
Exploded View and Bill of Materials.....	3
National Standards.....	3
Signal Words.....	4
Safety Instructions.....	4
Installing the Rack Arms.....	5
Using a BBL-OC-4 Lifter Equipped with Rack Arms.....	5
Record of Satisfactory Condition.....	6
Inspections & Maintenance.....	6
Accessory Equipment.....	6
Labeling Diagram.....	7
Limited Warranty.....	8

SPECIFICATIONS (47-007-056)

Specifications for the model BBL-OC-RK-A rack arms for BBL-OC-4 bulk bag lifters are provided on Vestil's website. To access the appropriate specifications document, navigate to this webpage: <https://www.vestil.com/product.php?FID=1711>. Click the "Specifications" tab. Scroll the page to the entry for model BBL-OC-RK-A, and click the button in the PDF column that looks like a pencil inside a box. A PDF file will open. This file is the specifications document. Print a copy of the document and keep it with your copy of this manual. The following is a copy of the specifications document.

BULK BAG LIFTER RACK ARMS - BBL-OC-RK-A

*** ANY ADDITIONS, DELETIONS, OR OMISSIONS MUST BE CORRECTED ON THIS DRAWING AS THIS DRAWING WILL BE CONSIDERED ALL INCLUSIVE ***
ALL GRAPHICS PROVIDED ARE FOR REFERENCE ONLY. IF CERTAIN DIMENSIONS ARE CRITICAL PLEASE VERIFY THOSE DIMENSIONS WITH YOUR SALESPERSON

APPROX WEIGHT: 31.44 lbs.
DOES NOT INCLUDE WEIGHT OF POWER OR PACKAGING!!!

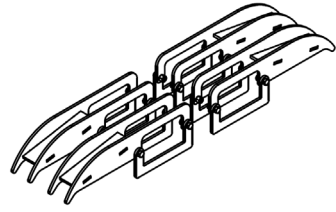

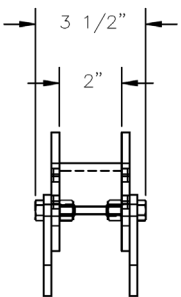

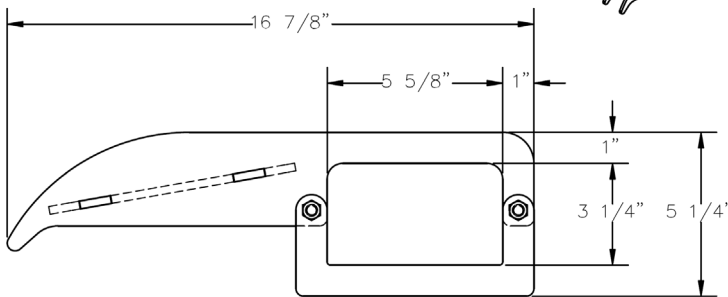

DIMENSION TOLERANCE ± 1/4"

STANDARD FEATURES

MODEL NUMBER IS: BBL-OC-RK-A
OVERALL LENGTH IS: 16 7/8"
OVERALL WIDTH IS: 3 1/2"
OVERALL HEIGHT IS: 5 1/4"
POCKET OPENING IS: 5 5/8" L x 3 1/4" H
4 RACK ARMS INCLUDED PER KIT
TOUGH BAKED IN POWDER COATED YELLOW FINISH

SPECIAL FEATURES

NONE

APPROVAL	I, THE UNDERSIGNED, AGREE THAT THE PRODUCT AS REPRESENTED SATISFIES DESIGN AND DIMENSION REQUIREMENTS. I ALSO ACKNOWLEDGE MY DUTY TO CONFIRM PRODUCT AND INSTALLATION COMPLIANCE WITH ALL APPLICABLE FEDERAL, STATE AND LOCAL REGULATIONS AND STANDARDS.	
	UNITS REQUIRING APPROVAL DRAWINGS OR MODIFIED ARE NON-RETURNABLE	
	[] As drawn [] As marked	
	Signed: _____	Date: _____
Printed Name: _____		
LEAD TIME WILL START UPON RECEIPT OF SIGNED APPROVAL DRAWING		
DISTRIBUTOR'S NAME:	P.O.#	
VESTIL MANUFACTURING		W.O.#
DRAWN BY: JGP	DATE: 3/30/2021	SALES: X
REFERENCE: X	SCALE: 1:4	FILE NAME:
QUOTED LEAD TIME: X	QUOTE #	47-007-056

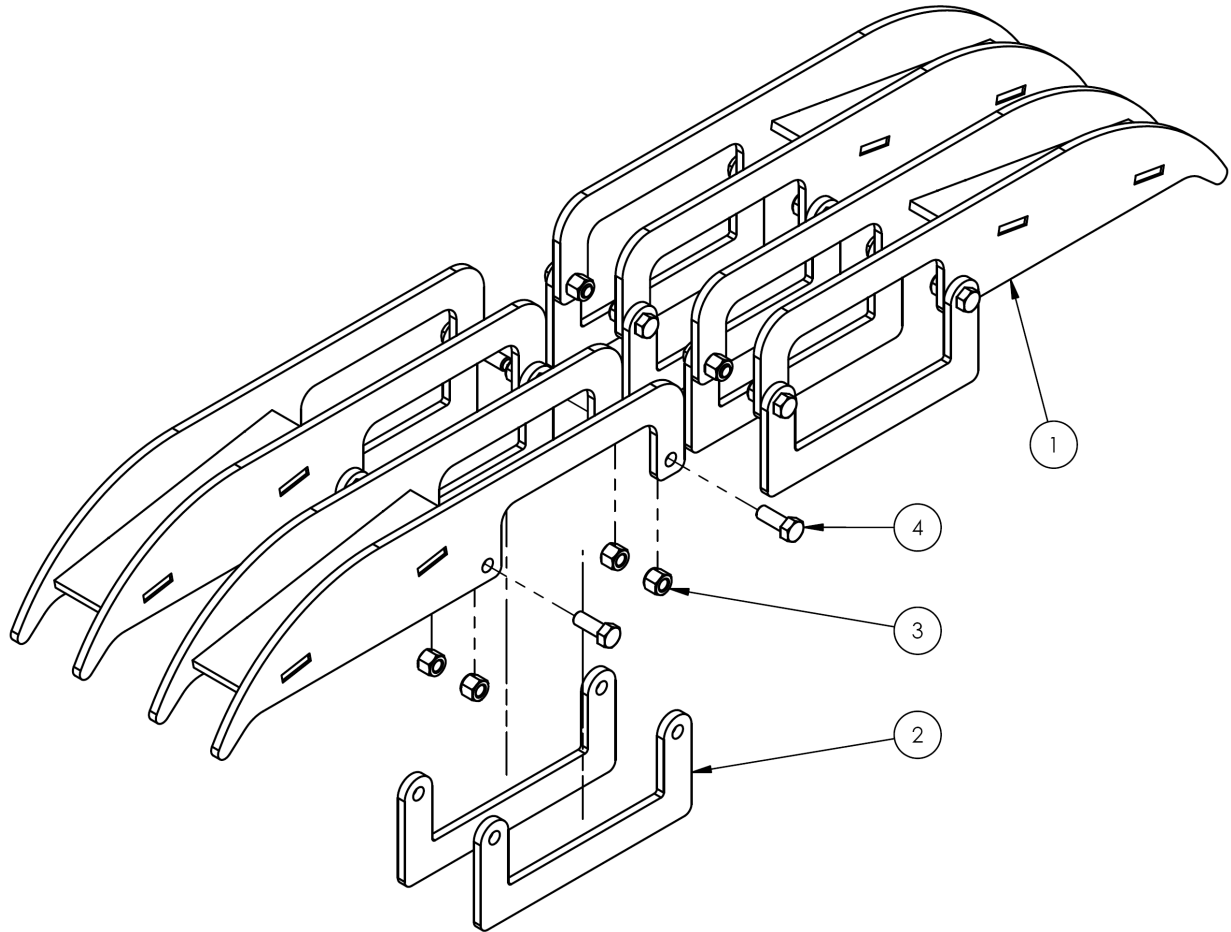
EXPLODED VIEW AND BILL OF MATERIALS (47-006-056)



ITEM	PART NO.	DESCRIPTION	QTY.
1	47-514-030	WELDMENT, FRAME, LIFTER RACK ARMS	4
2	47-014-056	FRAME, RACK ARM HINGE	8
3	37024	NYLON INSERT LOCK NUT, GRADE 2, ZINC FINISH, 3/8"-16	16
4	11105	HEX BOLT, GRADE A, ZINC PLATED, 3/8"-16 X 1"	16

NATIONAL STANDARDS

US OSHA Rule 1910.178 (29 CFR 1910.178; the "Rule") classifies a BBL-OC-4 bulk bag lifter, with or without rack arms installed, as a front end attachment whenever it is mounted on the forks of a lift truck. The Rule incorporates American National Standard ANSI/ITSDF B56.1 (the "Standard"). The Standard is published by the Industrial Truck Standards Development Foundation on its website where it is freely downloadable at <http://www.itsdf.org/cue/b56-standards.html>. Before putting a BBL-OC-4 lifter into service, you must acquire a copy of the Standard. Apply all relevant parts of Part II: For the User. If instructions provided in this manual conflict with the Standard, then apply the instructions in the Standard. Vestil requests that you immediately bring such conflicts to the attention of its [TECHNICAL SERVICE](#) personnel. Contact information for [TECHNICAL SERVICE](#) appears on the cover page of this manual.

SIGNAL WORDS

This manual uses SIGNAL WORDS to indicate the likelihood of personal injuries, as well as the probable seriousness of those injuries, if the product is misused in the ways described. Other signal words call attention to uses of the product likely cause property damage. The following are signal words used in this manual and their definitions.

 DANGER	Identifies a hazardous situation which, if not avoided, WILL result in DEATH or SERIOUS INJURY . Use of this signal word is limited to the most extreme situations.
 WARNING	Identifies a hazardous situation which, if not avoided, COULD result in DEATH or SERIOUS INJURY .
 CAUTION	Indicates a hazardous situation which, if not avoided, COULD result in MINOR or MODERATE injury.
NOTICE	Identifies practices likely to result in product/property damage, such as operation that might damage the product.

SAFETY INSTRUCTIONS

Vestil strives to identify foreseeable hazards associated with the use of its products. However, no manual can address every conceivable risk. The most effective way to avoid injury is to exercise sound judgment when assembling, using, inspecting, and maintaining this crane.

WARNING

Risks of serious personal injuries or death.

- **Read this manual in its entirety before assembling, using, inspecting or servicing the product.** Read the manual to refresh your understanding of use, inspection, and maintenance procedures as necessary. A copy of this manual should always be available to all persons who assemble, use, inspect and/or maintain this device.
- Review the safety messages included on labeling, and in the manuals, of devices used with this bulk bag rack: bulk bag and forklift.
- Inspect & maintain the rack as instructed in the [INSPECTIONS & MAINTENANCE](#) section on p. 6. Do not use the rack unless it is in [SATISFACTORY CONDITION](#). See [RECORD OF SATISFACTORY CONDITION, p. 6](#).
- DO NOT remove or obscure any label. Before using the rack, confirm that all labels are in place and easily readable from a reasonable distance. See [LABELING DIAGRAM](#) on p. 7.
- DO NOT allow people to ride in the bulk bag or on the rack.
- DO NOT lift more than the capacity/rated load of this rack or the bulk bag, whichever is smaller. The capacity of the rack is 1,000 pounds (454.5 kg). The capacity of Vestil's FAB-H bulk bag is 3,300 pounds (1500kg). If this rack is used to hold and move an FAB-H bag, the bag and its contents must not weight more than 1,000 pounds.
- Before mounting a bulk bag on the rack, inspect the bulk bag handles and the bag. Confirm that all parts are in good condition. DO NOT use the lifter to support or transport a bag UNLESS the handles and bag are undamaged.
- DO NOT lift or travel with a load elevated more than necessary to avoid contact with the ground. Bag contents might shift during transport so travel slowly. Avoid sudden stops to minimize load swing. Turn slowly and carefully. Make sure that the travel path is clear of persons and obstacles before transporting a bulk bag with this rack.
- Use this product consistently with both the relevant portions of the current revision of ANSI/ITSDF B56.1 and your lift truck operator training.
- DO NOT pull or drag the rack. ONLY use the rack to load and transport bulk bags.
- DO NOT leave an elevated load/rack unattended. Always land the rack before leaving it.
- DO NOT modify the rack in any way. Modifications automatically void the [LIMITED WARRANTY](#) (on p. 8) and might make the rack unsafe to use.

INSTALLING THE RACK ARMS

Step 1: Set rack arms (47-514-030) on top of the fork channels of your BBL-OC-4 lifter inside the central opening of the lifter. The arms should be a few inches away from the cross bars.

Step 2: Attach 2 hinge arms (47-014-056) to each rack arm with 3/8"-16x1" (11105) hex bolts and 3/8"-16 Nylock nuts (37024). Tighten the bolts and nuts.

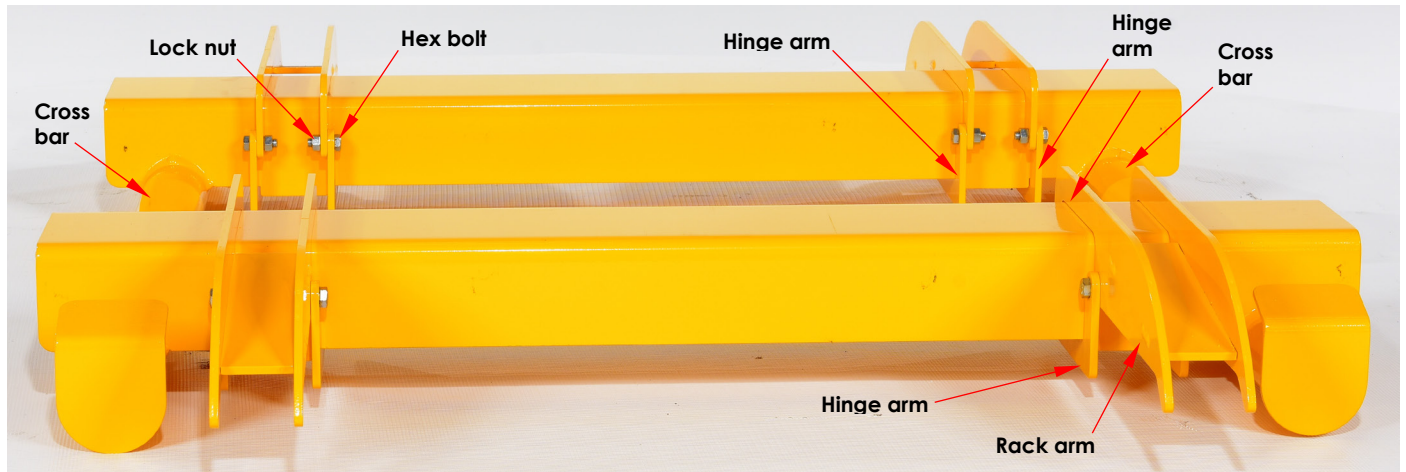

USING A BBL-OC-4 LIFTER EQUIPPED WITH RACK ARMS

A BBL-OC-4 bulk bag lifter equipped with BBL-OC-RK-A rack arms can be set on the support tubes of a BBL-RK-72. First, the lifter must be mounted on the forks of a forklift.

NOTE: Capacity information appears in the [SPECIFICATIONS](#) section on p. 2 as well as on label #1153. See [LABELING DIAGRAM](#) on p. 7. The capacity of a properly assembled and maintained rack unit is 1,000 lb. (454.5kg). Do not apply loads to the rack that exceed the capacity of your unit. The forklift used with this rack must be able to support the combined weight of the rack, the bulk bag, and the material inside the bulk bag.

Mounting the lifter on forks: Refer to the *USING THE LIFTER* instructions in your BBL-OC-4 owner's manual.

- Adjust the forks to match the locations of the fork channels of the lifter (BBL-OC-4).
- Insert the forks through both fork channels.
- Wrap the carriage chain around part of the fork carriage. Attach the snap hook to the quick link or to a link in the chain. *There must be no slack in the chain!* The lifter must not be able to slide on the forks.
- Elevate the forks. Attach a fabric hopper/bulk bag to the lifter. Attach each of the (4) straps of the bag to one of the arms of the lifter. Slide the straps over the retainers and seat them in the strap slots. Material can be loaded into the bag through the central opening of the lifter.
- Drive toward the open side of a BBL-RK-72 rack. Lower the forks to set the rack arms on top of the bag mounting weldments.

Central opening allows attached bulk bag to be easily filled.

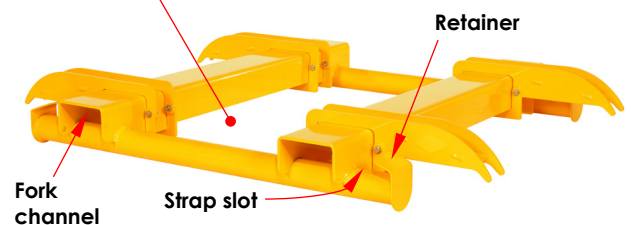

[OSHA rule 29 CFR 1910.178](#) applies to front end attachments. The rule requires that you contact the manufacturer of your fork truck (or a professional engineer). The manufacturer must determine how using the lifter affects the capacity, operation, and maintenance of your fork truck. The analysis can also be performed by a professional engineer. Afterwards, plates, tags, labels, etc. affixed to the truck must be updated. The truck should also be marked to identify this BBL-4 attachment and to display the approximate weight of the truck and attachment combination at maximum elevation with a laterally centered load.

RECORD OF SATISFACTORY CONDITION (THE “RECORD”)

Before putting the lifter equipped with rack arms into service, record its appearance. Thoroughly photograph the unit so that all features are clearly visible. Take close range photographs of each label and/or tag applied to the unit, the carriage chain and snap hook, and all fasteners, hinge arms, and rack arms. Collect the photographs in a file. The file is a record of the unit in satisfactory condition. Do not use the lifter equipped with rack arms unless all parts are in satisfactory condition.

INSPECTIONS & MAINTENANCE

Compare the results of each inspection to the [RECORD](#), as well as the RECORDS of your BBL-OC-4 lifter and BBL-RK-72 rack, to determine whether all parts of the lifter, rack, and rack arms are in satisfactory condition. DO NOT use the lifter, rack, or rack arms unless each product is in satisfactory condition. Only use manufacturer-approved replacement parts to restore the products to satisfactory condition. Never make temporary repairs of damaged or missing parts. **DON'T GUESS! If you have any questions about the condition of your unit, contact the [TECHNICAL SERVICE](#) department.** The phone number is provided on the cover page of this manual. Purely cosmetic changes, such as chipped paint, are not changes from satisfactory condition. However, unprotected steel rusts so touchup paint should be applied to all areas where the finish is damaged as soon as the damage occurs. Left unaddressed, rusting could compromise the soundness of the metal and create a safety hazard.

Inspect the following **at least 1 time per month**:

- 1) Rack arm weldments, hinge arms, and all fasteners: Closely examine each item for cracks, bends, twists, elongations, thinned areas, and rusting/corrosion, or significant wear. Inspect the fork channels of the lifter when the rack arms attach to them. Look for significant rusting/corrosion, damaged paint, and other damage.
- 2) Labels & tags: Confirm that each label and/or tag is present and easily readable.

Maintain the rack by replacing damaged hardware, applying touchup paint to areas where the surface coating is damaged, and replacing components that are not in satisfactory condition.

ACCESSORY EQUIPMENT

A selection of equipment is available for use with BBL-RK-72 bulk bag racks:

- **BBL-OC-4**: Fork-mountable bulk bag lifter with an open center. The lifter provides solutions for both loading and transporting bulk bags.
- **BBL-OC-RK-A**: Steel arms that fasten to an open center bulk bag lifter (BBL-OC-4). These arms allow an open center bulk bag lifter (BBL-OC-4) to be removably mounted on the upper supports of a BBL-RK-72 support rack. Hang a bulk bag from the lifter. The filled bulk bag can be moved while the rack remains in place simply by inserting the forks of your lift truck through the fork channels of the lifter and lifting it free of the rack.
- **BBL-B001**: Complete open center bulk bag kit. The kit includes a bulk bag lifter (BBL-OC-4), 4 lifter mounting arms (BBL-OC-RK), and a bulk bag rack (BBL-RK-72). This kit provides the user with an optimally versatile bulk storage system.

LABELING DIAGRAM

Label content and location are subject to change so your product might not be labeled exactly as shown. Compare the diagram below to the [RECORD OF SATISFACTORY CONDITION](#) of your BBL-OC-4 lifter, BBL-RK-72 rack, and BBL-OC-RK-A rack arms. If differences between applied labeling and this diagram exist, contact [TECHNICAL SERVICE](#). Replace all labels that are damaged, missing, or not easily readable (e.g. faded). To order replacement labels, or to inquire whether your unit is properly labeled, contact the [TECHNICAL SERVICE AND PARTS DEPARTMENT](#) online at http://www.vestilmfg.com/parts_info.htm or by calling (260) 665-7586 and asking for the Parts Department.

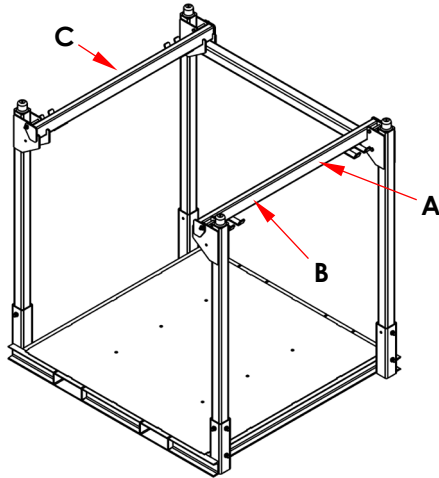

A: Label 1153

MODEL / MODÉLO / MODÈLE _____
WEIGHT / PESO / MASS _____
CAPACITY / CAPACIDAD / CAPACITÉ _____
SERIAL / SERIE / SÉRIE _____
UNITS: 2.2 lb. = 1kg 1" (or 1in.) = 2.54cm 1153

B: Label 1049

⚠ WARNING	
<p>Improper use of this fork attachment might result in death or serious injury.</p> <ul style="list-style-type: none"> Using this front end attachment affects lift truck center of gravity. Before using this fork attachment, US Federal regulation 29 CFR 1910.178 requires you to contact the manufacturer of your lift truck and request: <ol style="list-style-type: none"> Written approval [29 CFR 1910.178(a)(4)] Markings for (fork) lift truck that: <ul style="list-style-type: none"> Identify the attachment; Give approximate weight of truck and attachment at maximum elevation with laterally-centered load. [29 CFR 1910.178(a)(5)]. DO NOT use UNTIL lift truck is marked with corrected capacity tags. CAPACITY OF TRUCK & ATTACHMENT COMBINATION MIGHT BE LESS THAN CAPACITY OF ATTACHMENT. CONSULT TRUCK CAPACITY TAG/LABEL. 	
1049	<small>rev 1120</small>

C: Label 658

⚠ WARNING	⚠ ADVERTENCIA	⚠ AVERTISSEMENT	658 <small>rev 0808</small>
Do not operate or move with unstable loads DO NOT LOAD beyond rated capacity DISTRIBUTE LOAD EVENLY DO NOT sit or ride	No use a mueva con cargas inestables No cargue mas de la capacidad tasada DISTRIBUYA LA CARGA A NIVEL NO SE SIENTE o vaya en el carro	Ne pas utiliser avec une charge instable NE PAS CHARGER au-delà du débit nominale DISTRIBUER la charge régulièrement NE PAS VOUS ASSEoir OU VOUS PROMENER sur le chariot	

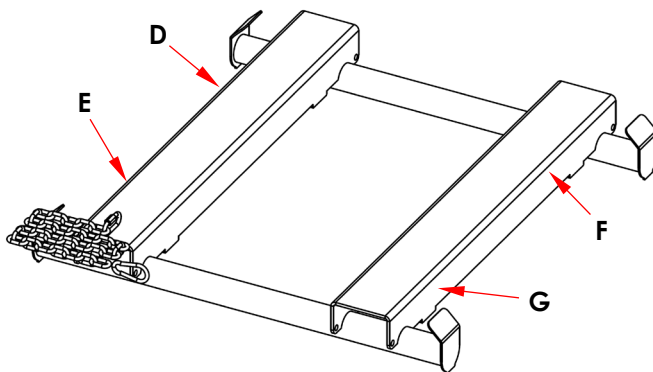

D: Label 1153

MODEL / MODÉLO / MODÈLE _____
WEIGHT / PESO / MASS _____
CAPACITY / CAPACIDAD / CAPACITÉ _____
SERIAL / SERIE / SÉRIE _____
UNITS: 2.2 lb. = 1kg 1" (or 1in.) = 2.54cm 1153

E: Label 218

⚠ WARNING	⚠ ADVERTENCIAS	218 <small>rev 0910</small>
<p>Improper use might result in death or serious personal injury. Attach device to fork carriage with safety chain/strap.</p> <ul style="list-style-type: none"> Drive lift truck forward until forks contact ends of fork pockets. Chain/straps must not be able to disconnect (slide free) from carriage. Safety chain/strap must be taut. Connect chain/strap to carriage via shortest line. 	<p>El uso impropio puede resultar en muerte o heridas personales. Atar aparato al mástil del montacargas con cadenas/correas.</p> <ul style="list-style-type: none"> Maneje el montacargas para adelante hasta que las cuñas hagan contacto con la orilla del bolsillo de las cuñas. La cadenas y correas no deben de deslizarse (soltarse) del mástil del montacargas. La cadena/correa de seguridad debe de estar apretado. Asegure la cadena/correa al mástil via la ruta mas corta. 	

F: Label 675

⚠ WARNING	⚠ ADVERTENCIA	675 <small>rev 1213</small>
<ul style="list-style-type: none"> DO NOT exceed rated capacity DO NOT use if damaged, malfunctioning, or missing parts DO NOT lift people OR lift loads over people DO NOT raise load higher than necessary DO NOT leave a suspended load unattended DO NOT use lifter unless you read and understand the owner's manual DO NOT alter OR modify lifter DO NOT remove OR obscure any label STAY CLEAR of suspended loads Secure load before using this device 	<ul style="list-style-type: none"> NO exceda la capacidad tasada NO USE is las partes estan dañadas, no funcionan correctamente o faltan partes. NO eleve al personal o eleve cargas sobre el personal NO eleve la carga mas alto de lo necesario NO deje desatendida una carga que este suspendida NO use el elevador a no ser que haya leído y entendido las instrucciones del manual del propietario NO altere o modifique el elevador NO quite u oscurezca ninguna etiqueta MANTENGASE alejado de las cargas suspendidas Asegure la carga antes de usar este dispositivo 	

G: Label 1049

⚠ WARNING	
<p>Improper use of this fork attachment might result in death or serious injury.</p> <ul style="list-style-type: none"> Using this front end attachment affects lift truck center of gravity. Before using this fork attachment, US Federal regulation 29 CFR 1910.178 requires you to contact the manufacturer of your lift truck and request: <ol style="list-style-type: none"> Written approval [29 CFR 1910.178(a)(4)] Markings for (fork) lift truck that: <ul style="list-style-type: none"> Identify the attachment; Give approximate weight of truck and attachment at maximum elevation with laterally-centered load. [29 CFR 1910.178(a)(5)]. DO NOT use UNTIL lift truck is marked with corrected capacity tags. 	
1049	<small>rev 1118</small>



LIMITED WARRANTY

Vestil Manufacturing Corporation ("Vestil") warrants this product to be free of defects in material and workmanship during the warranty period. Our warranty obligation is to provide a replacement for a defective, original part covered by the warranty after we receive a proper request from the Warrantee (you) for warranty service.

Who may request service?

Only a warrantee may request service. You are a warrantee if you purchased the product from Vestil or from an authorized distributor AND Vestil has been fully paid.

Definition of "original part"?

An original part is a part used to make the product as shipped to the Warrantee.

What is a "proper request"?

A request for warranty service is proper if Vestil receives: 1) a photocopy of the Customer Invoice that displays the shipping date; AND 2) a written request for warranty service including your name and phone number. Send requests by one of the following methods:

<u>US Mail</u>	<u>Fax</u>	<u>Email</u>
Vestil Manufacturing Corporation 2999 North Wayne Street, PO Box 507 Angola, IN 46703	(260) 665-1339 <u>Phone</u> (260) 665-7586	info@vestil.com Enter "Warranty service request" in subject field.

In the written request, list the parts believed to be defective and include the address where replacements should be delivered. After Vestil receives your request for warranty service, an authorized representative will contact you to determine whether your claim is covered by the warranty. Before providing warranty service, Vestil will require you to send the entire product, or just the defective part (or parts), to its facility in Angola, IN.

What is covered under the warranty?

The warranty covers defects in the following original, dynamic parts: motors, hydraulic pumps, motor controllers, and cylinders. It also covers defects in original parts that wear under normal usage conditions ("wearing parts"), such as bearings, hoses, wheels, seals, brushes, and batteries.

How long is the warranty period?

The warranty period for original dynamic components is 1 year. For wearing parts, the warranty period is 90 days. Both warranty periods begin on the date Vestil ships the product to the Warrantee. If the product was purchased from an authorized distributor, the periods begin when the distributor ships the product. Vestil may, at its sole discretion, extend a warranty period for products shipped from authorized distributors by up to 30 days to account for shipping time.

If a defective part is covered by the warranty, what will Vestil do to correct the problem?

Vestil will provide an appropriate replacement for any covered part. An authorized representative of Vestil will contact you to discuss your claim.

What is not covered by the warranty?

The Warrantee (you) is responsible for paying labor costs and freight costs to return the product to Vestil for warranty service.

Events that automatically void this Limited Warranty.

- Misuse;
- Negligent assembly, installation, operation or repair;
- Installation/use in corrosive environments;
- Inadequate or improper maintenance;
- Damage sustained during shipping;
- Collisions or other accidents that damage the product;
- Unauthorized modifications: Do not modify the product IN ANY WAY without first receiving written authorization from Vestil.

Do any other warranties apply to the product?

Vestil Manufacturing Corp. makes no other express warranties. All implied warranties are disclaimed to the extent allowed by law. Any implied warranty not disclaimed is limited in scope to the terms of this Limited Warranty. Vestil makes no warranty or representation that this product complies with any state or local design, performance, or safety code or standard. Noncompliance with any such code or standard is not a defect in material or workmanship.