

Instructions for: BETA Tools Workstations

The guide on the following page(s) was provided by the supplier.
New Pig Corporation assumes no responsibility, obligation, or
liability in conjunction with the use or misuse of the information.



New Pig

One Pork Avenue
Tipton, PA 16684-0304

newpig.com

North America: **1-800-468-4647**

Europe: **+31 (0)76 596 92 50**

China: **+86-21-400 921 5178**

UK: **0800 919 900**



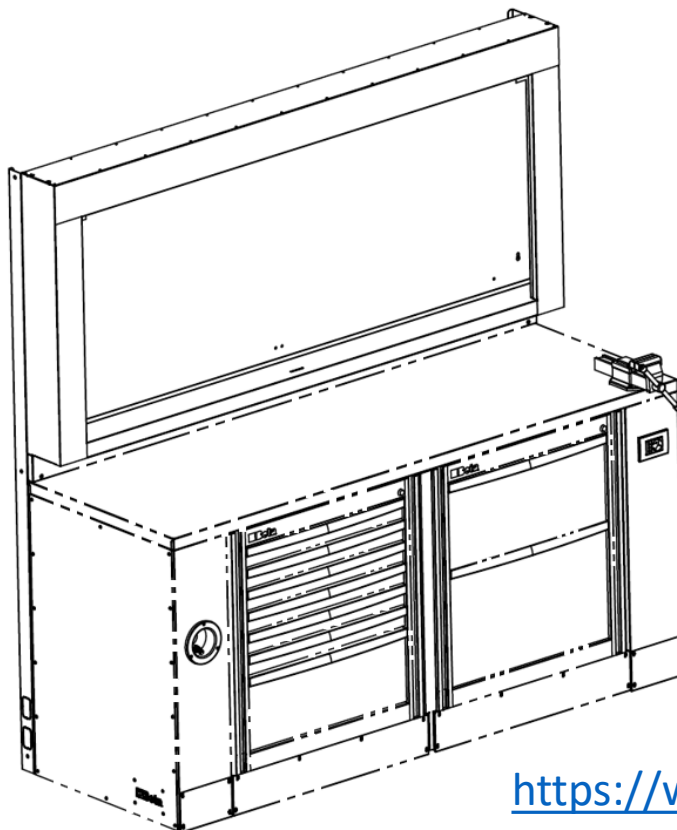

Outside North America: **+1-814-684-0101**

PIG, PIG logo are registered trademarks in USA and other countries. See tm.newpig.com



<https://www.beta-tools.com/it/rsc55>

| Pos | Code | Descrizione/ Description | Pcs . |
|-----|-----------|---|-------|
| 1 | 055000250 | PARETE PORTAUTENSILI con TAPPARELLA / Tool wall system with shutter | 4 |
| | | a) Supporti verticali laterali / Side vertical supports | 2 |
| | | b) Mascherina frontale sottoparete / Front cover | 1 |
| | | c) Parete portautensili / Tool wall system with shutter | 1 |

| | | | | | | | |
|-----------------------|---|-----------------------|---|-----------------------|---|---------------------------|---|
| A |  | B |  | C |  | D |  |
| M6 X 12 TCEI (4 pcs.) | | M5 X 12 TCEI (4 pcs.) | | M8 X 16 TCEI (6 pcs.) | | Washer Wide Band (4 pcs.) | |

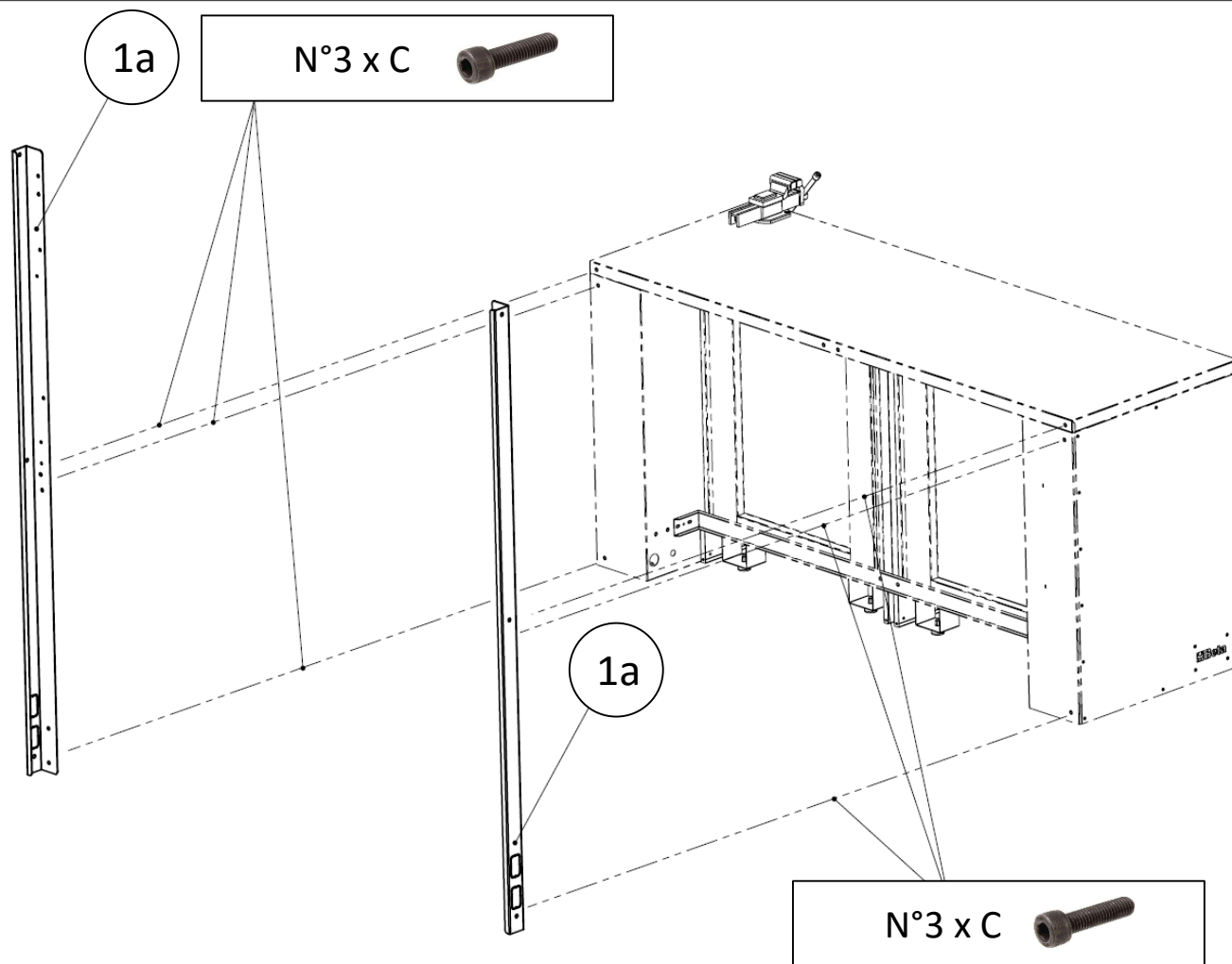

Non serrare completamente le viti dei supporti posteriori per agevolare il successivo montaggio della tapparella portautensili

Keep the bolts loosen and don't fasten them totally. It makes easier the mounting of the tool wall shutter

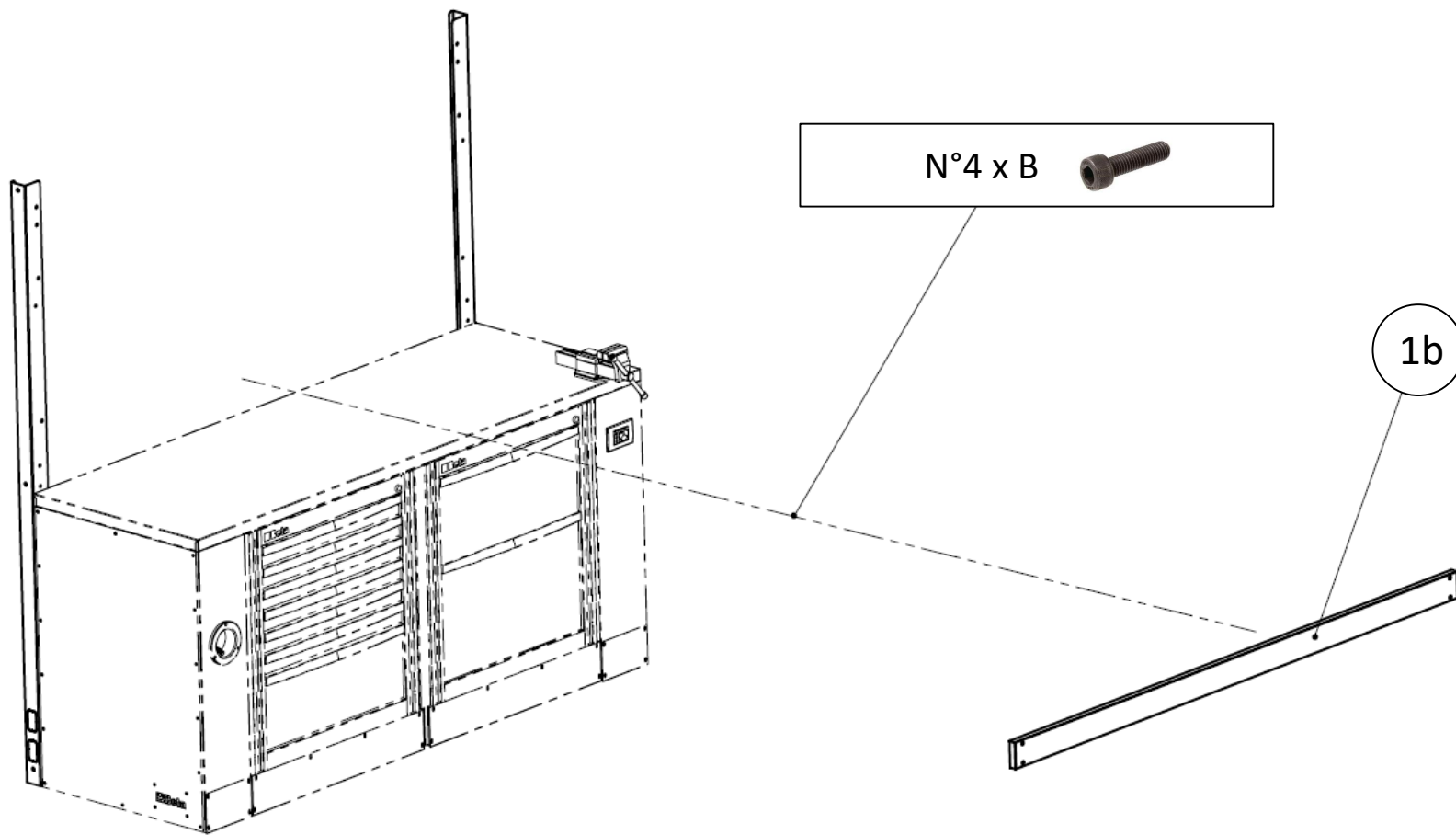

N°4 x A
+
N°4 x D



1c

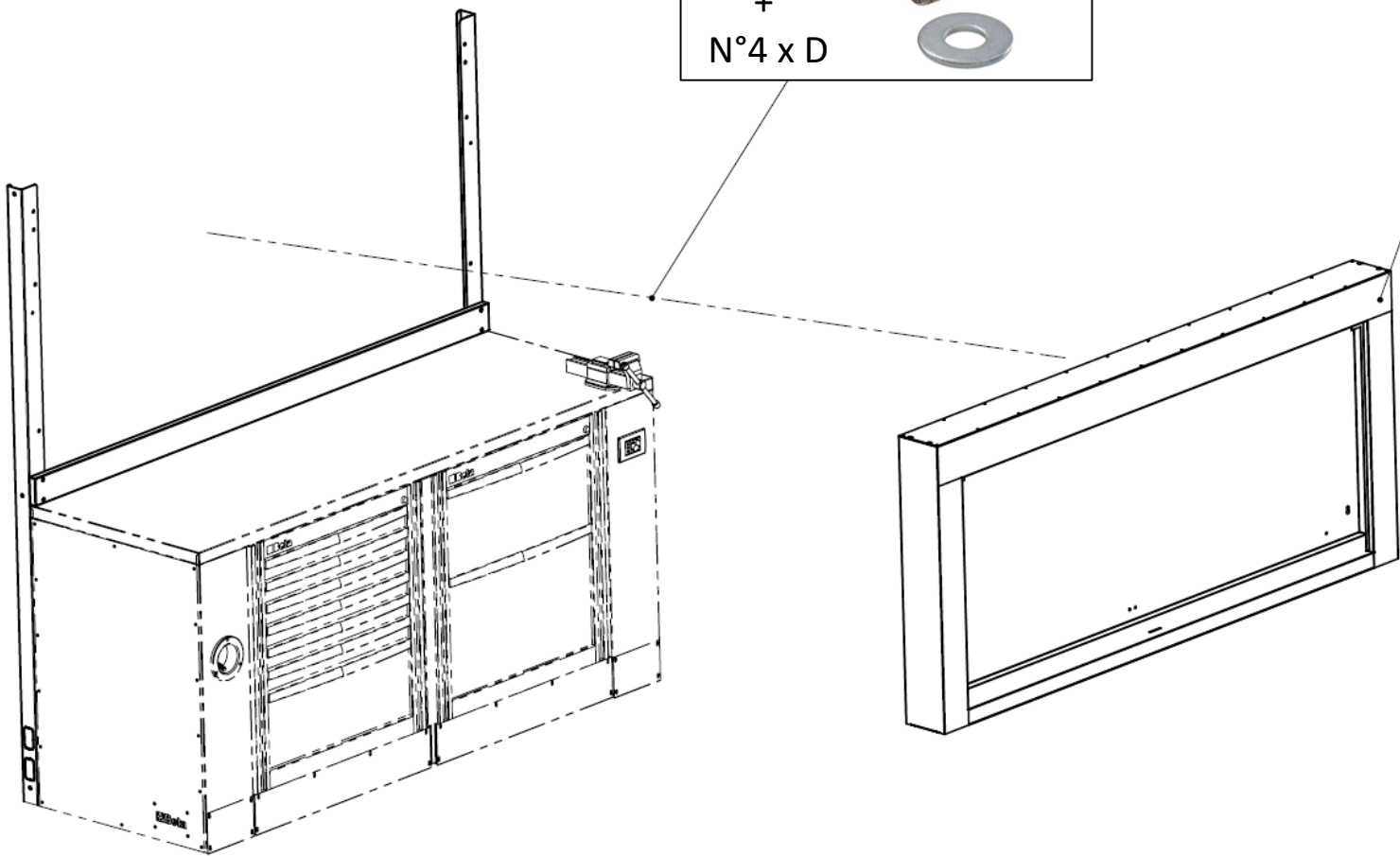

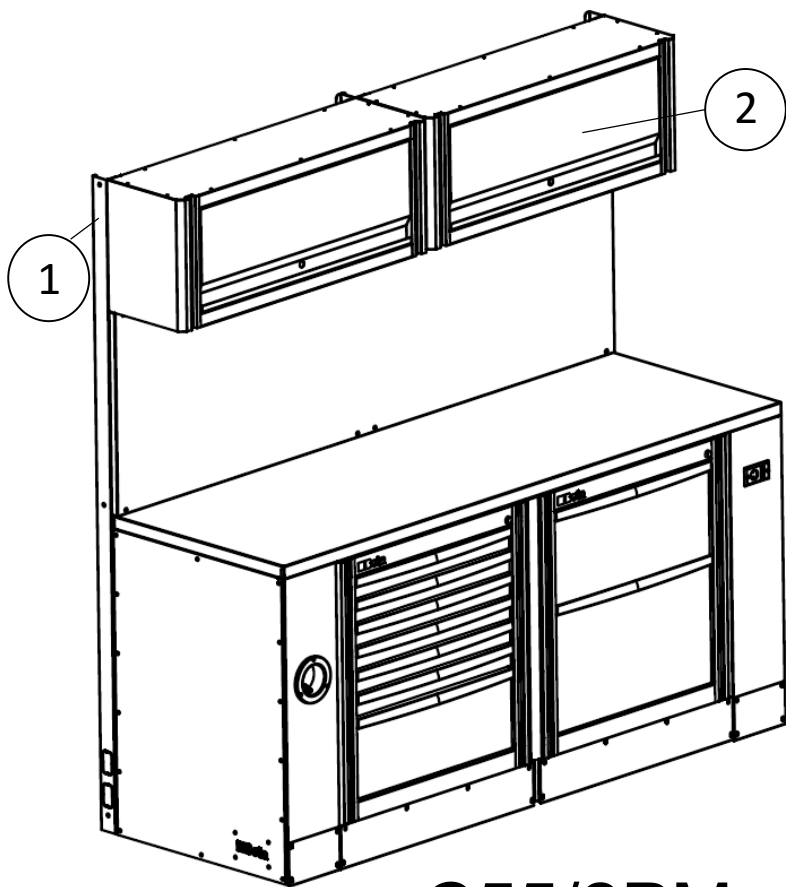

C55/2PM
055000301

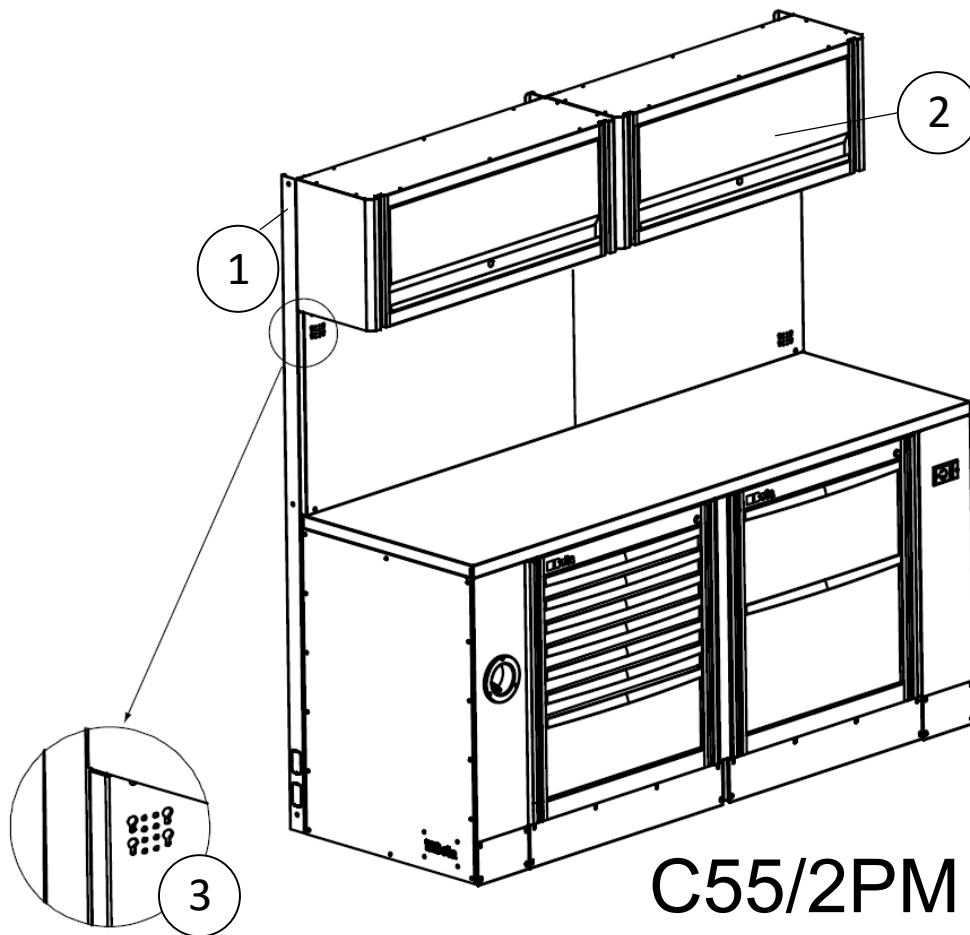

C55/2PM
055000301
+
C55/2PF

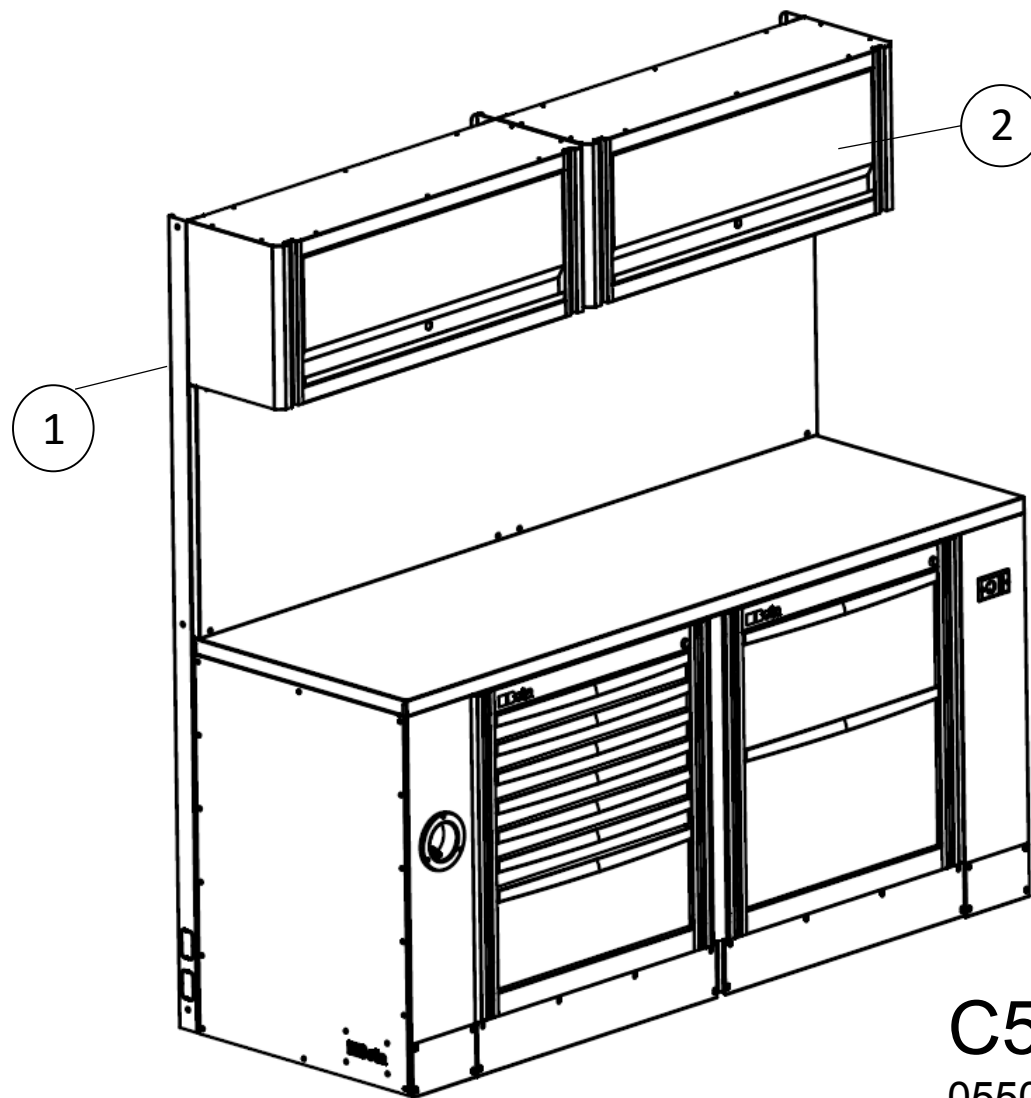



C55/2PM

055000301

| C55/2PM (cod. 055000301) | | | |
|--------------------------|-----------|--|-------|
| Pos | Code | Descrizione/ Description | Pcs . |
| 1 | 055000303 | SUPPORTO POSTERIORE SOSTEGNO PENSILE + PANNELLO / <i>Rear suspended cabinets support + cover panel</i> | 5 |
| | | a) Supporti verticali centrali / <i>Central vertical supports</i> | 1 |
| | | b) Supporti verticali laterali / <i>Side vertical supports</i> | 2 |
| | | c) Traverse posteriori / <i>Rear crossbeam</i> | 1 |
| | | d) Pannelli / <i>Cover panels</i> | 1 |
| 2 | 055000186 | PENSILI MURO RACING LINE GREY 1,0m / <i>1,0m suspended cabinets</i> | 2 |

| C55/2PF (cod. 055000310) | | | |
|--------------------------|-----------|---|---|
| 3 | 055000310 | PANNELLI FORATI PORTA ATTREZZI 1 m / <i>1,0m perforated tool panels</i> | 1 |

| | | | | | | | |
|---|---|---|---|---|--|---|---|
| A |  | B |  | C |  | D |  |
| | M6 X 12 TCEI (8 pcs.) | | M5 X 12 TCEI (12 pcs.) | | M8 X 16 TCEI (13 pcs.) | | Washer Wide Band (8 pcs.) |

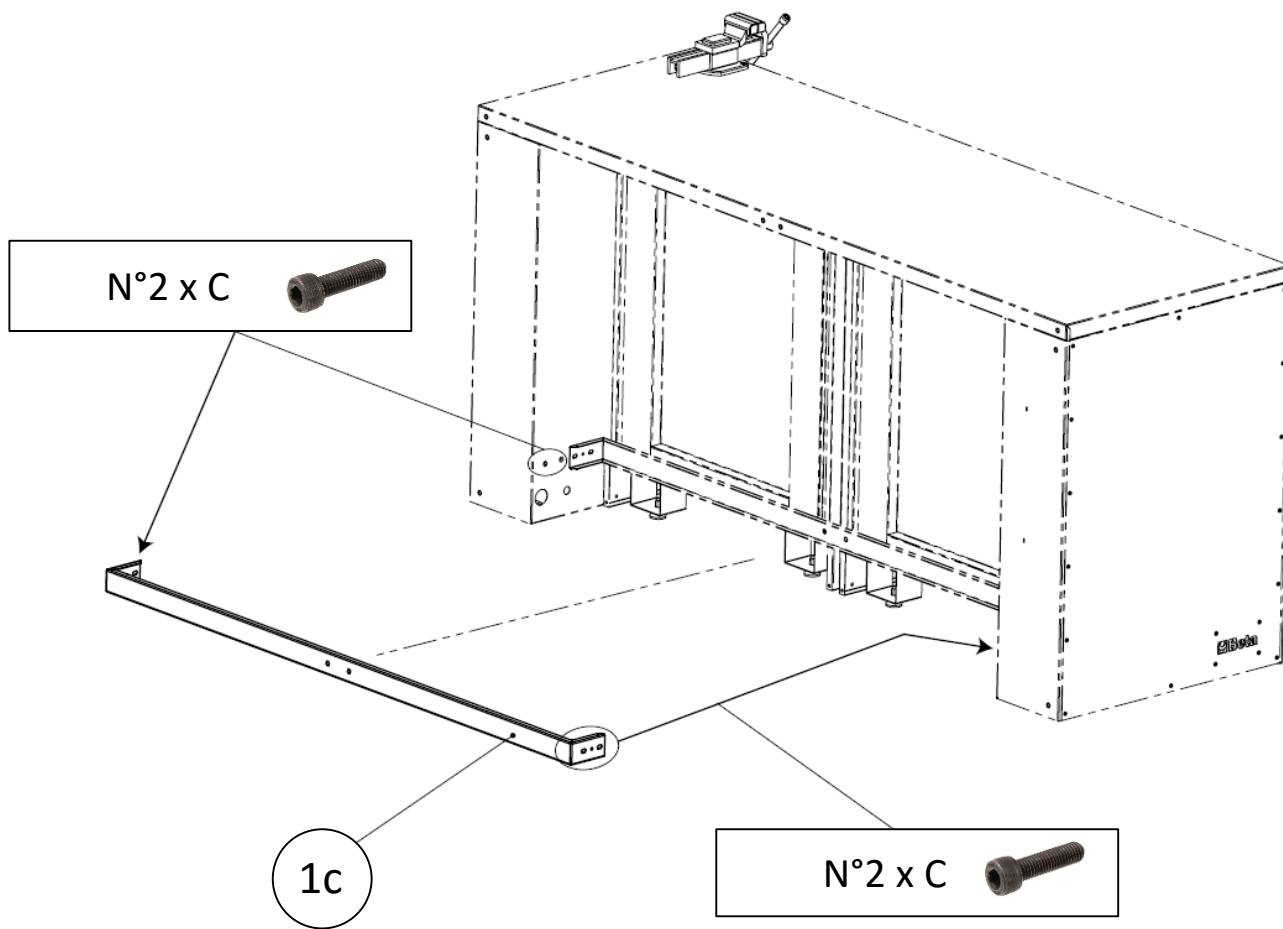

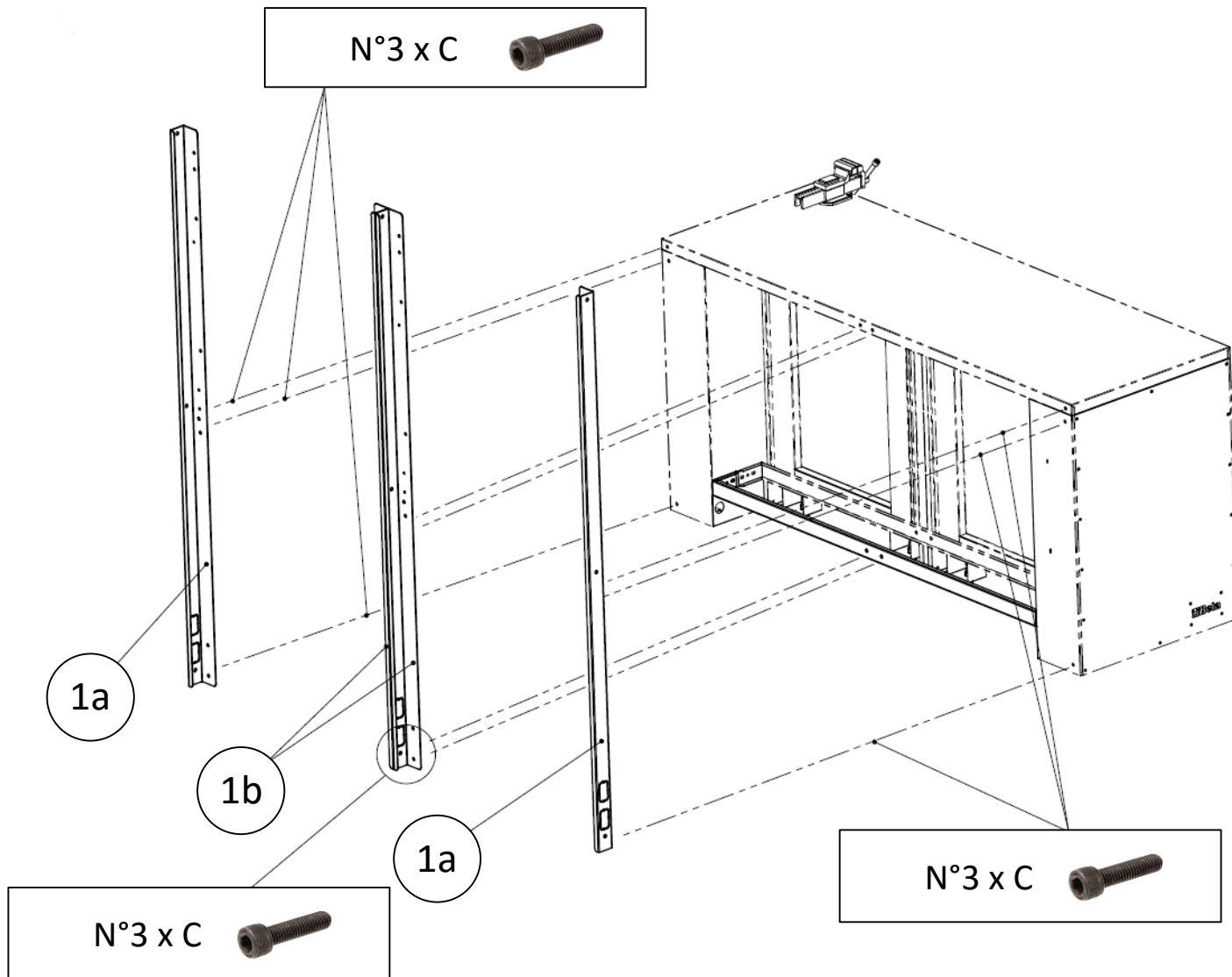

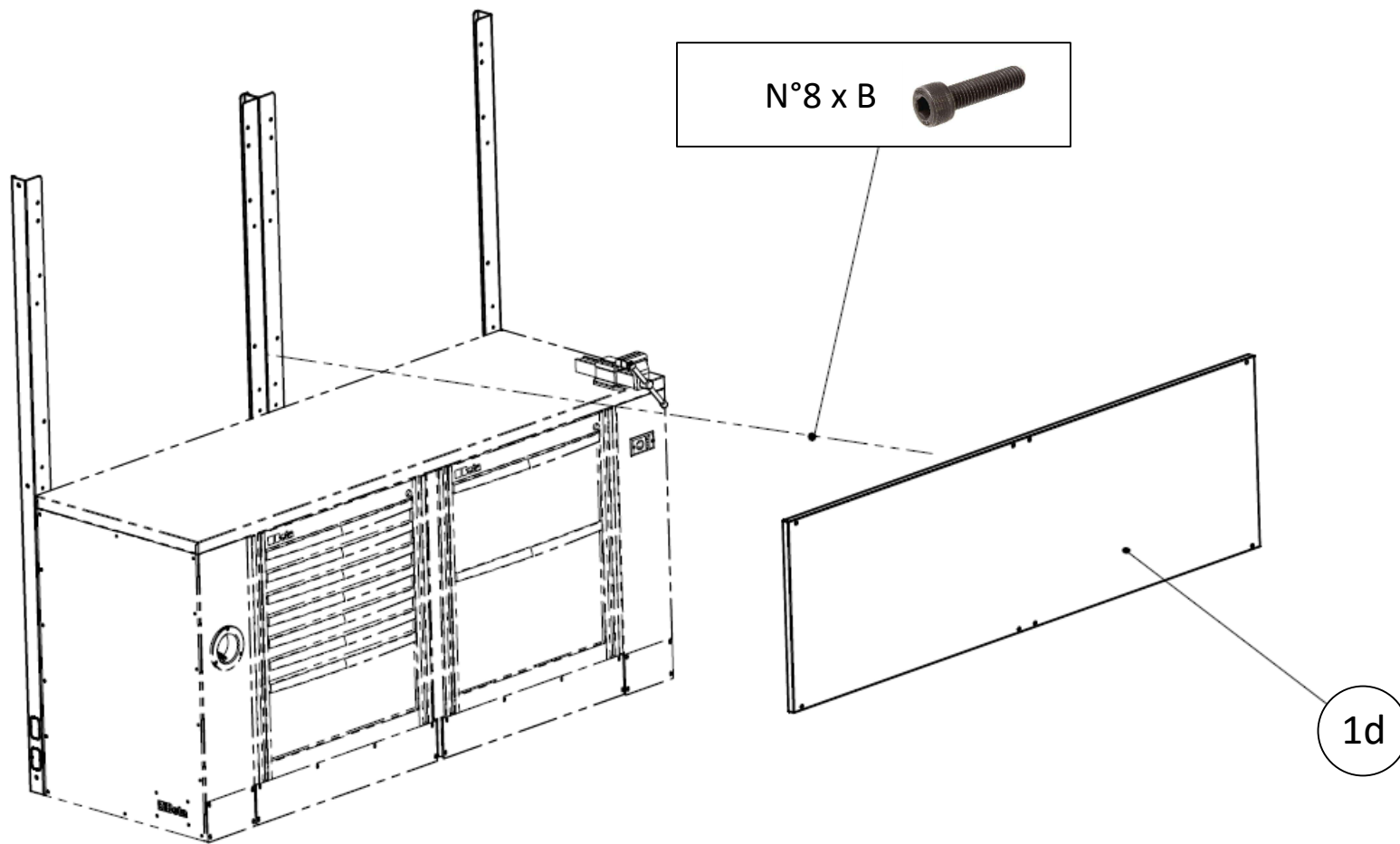

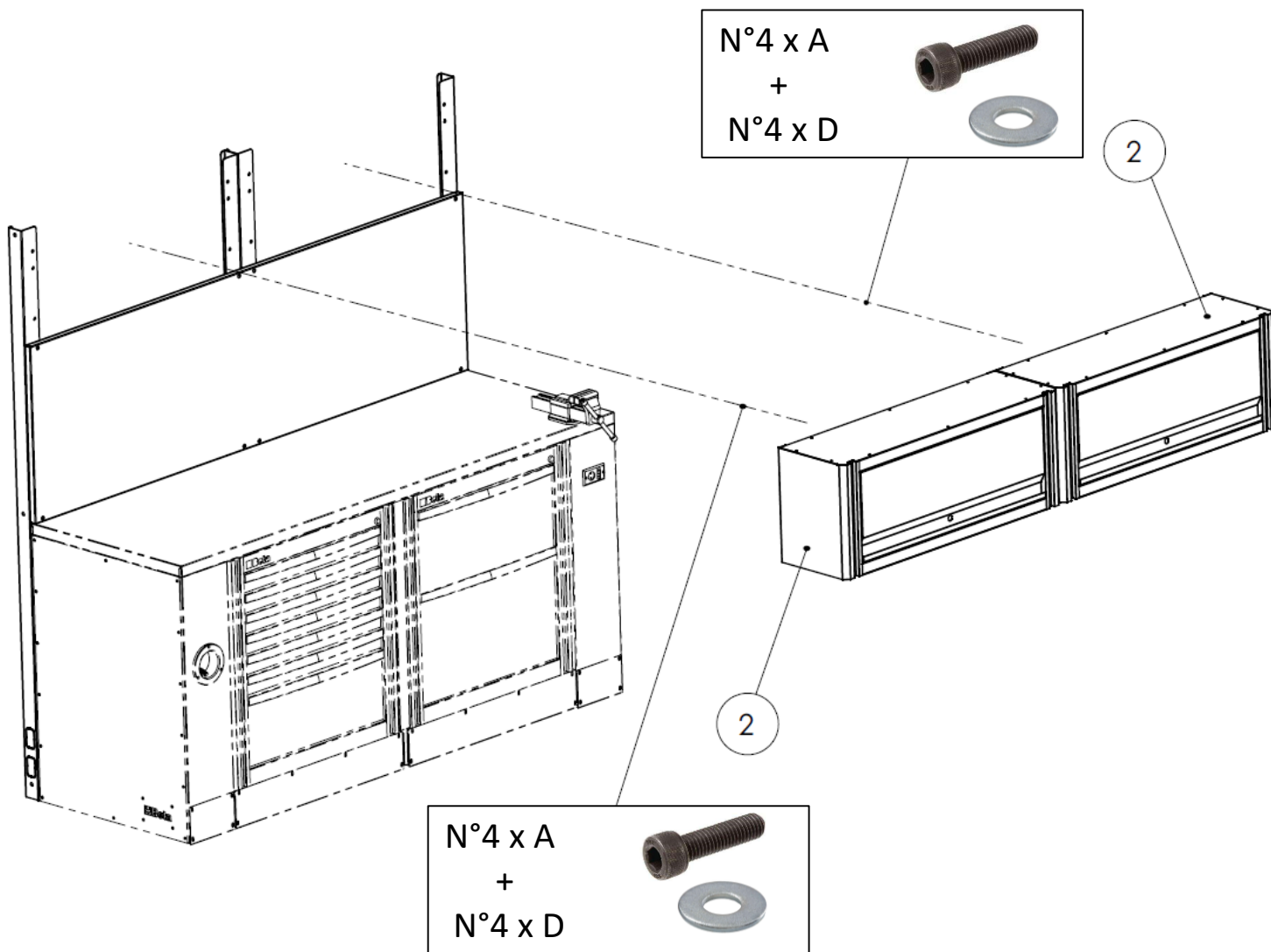

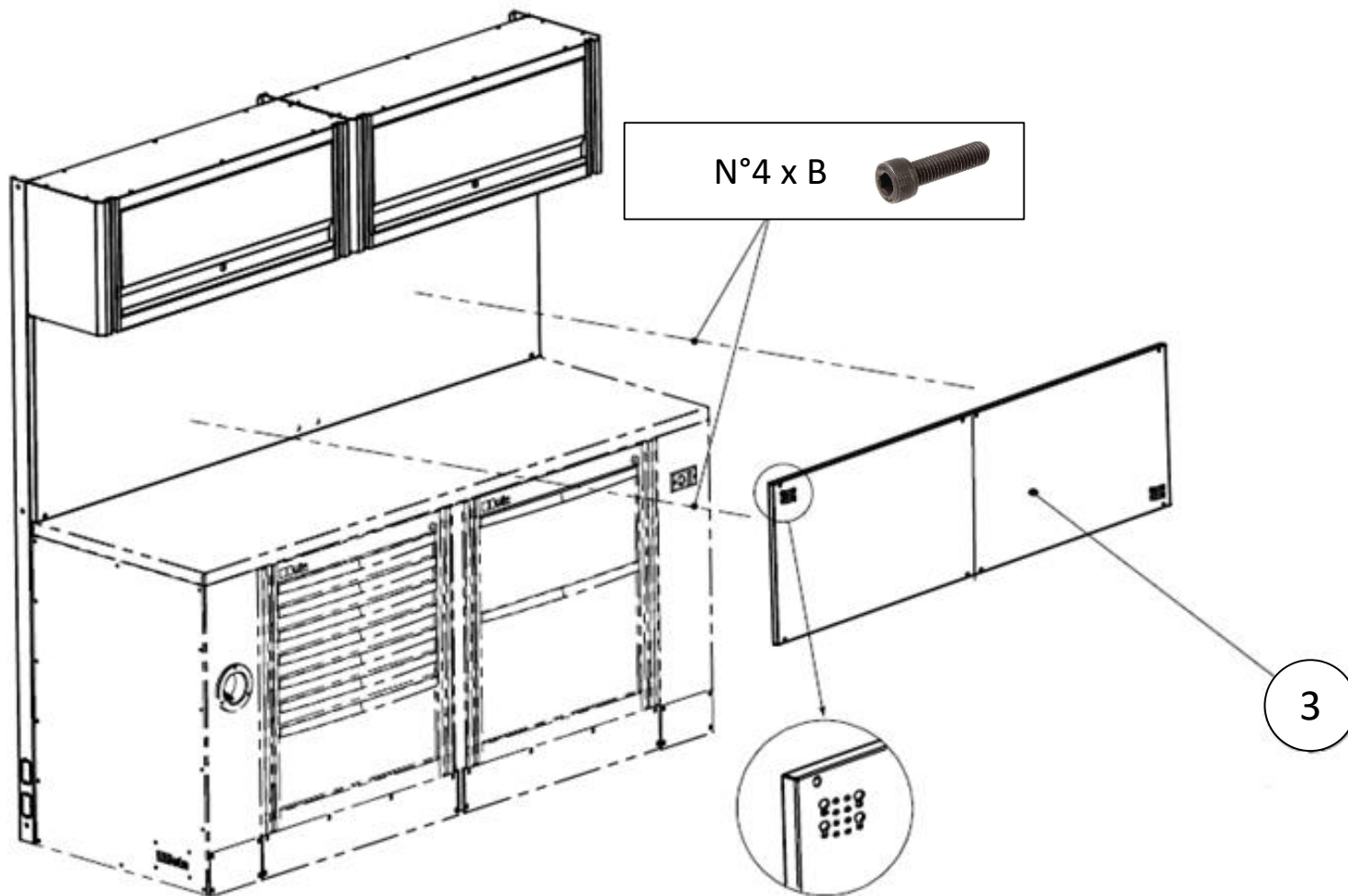

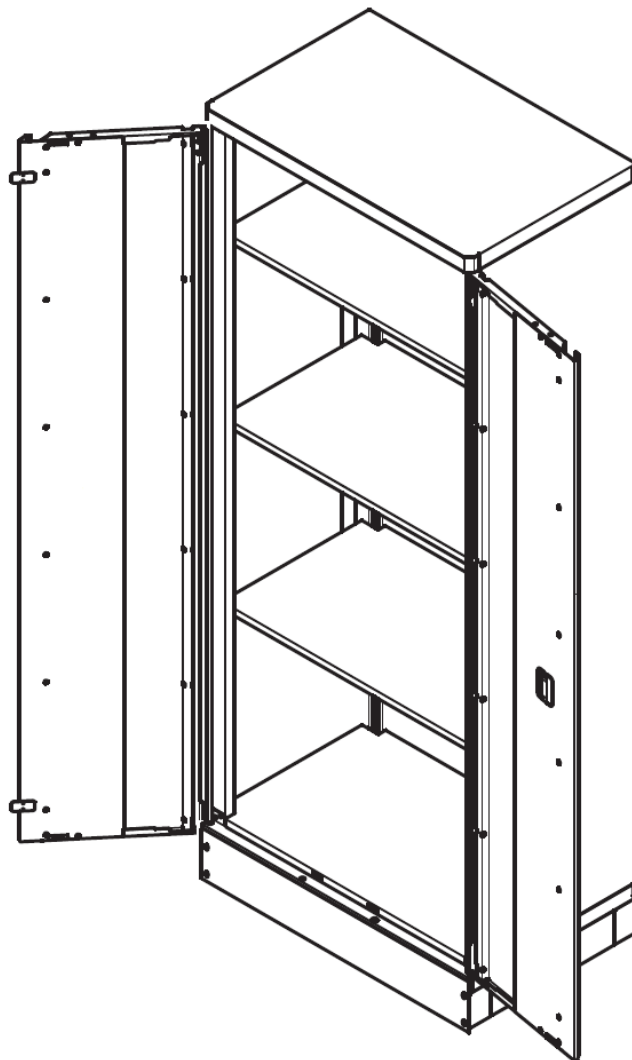

| Pos | Code | Descrizione/ Description | Pcs . |
|-----|------|--|-------|
| W1 | | BASI INFERIORI/ <i>Bottom basis</i> | 1 |
| W2 | | BASI SUPERIORI/ <i>Top basis</i> | 1 |
| W3 | | FIANCHI DESTRI / <i>Right sides</i> | 1 |
| W4 | | FIANCHI SINISTRI / <i>Left sides</i> | 1 |
| W5 | | SEMI PANNELLI POSTERIORI DESTRI / <i>Right rear half panels</i> | 1 |
| W6 | | SEMI PANNELLI POSTERIORI SINISTRI / <i>Left rear half panels</i> | 1 |
| W7 | | MENSOLE / <i>Shelves</i> | 3 |
| W8 | | FONDI / <i>Floor bases</i> | 1 |
| W9 | | ANTE DESTRA / <i>Right doors</i> | 1 |
| W10 | | ANTE SINISTRA / <i>Left doors</i> | 1 |
| W11 | | SUPPORTI BASE INFERIORE ANTERIORE / <i>Front base supports</i> | 1 |
| W12 | | SUPPORTI BASE INFERIORE POSTERIORE / <i>Rear base supports</i> | 1 |
| W13 | | SUPPORTI BASE INFERIORE LATERALE / <i>Side base supports</i> | 2 |

A



18 pcs.

B



4 pcs.

C



4 pcs.

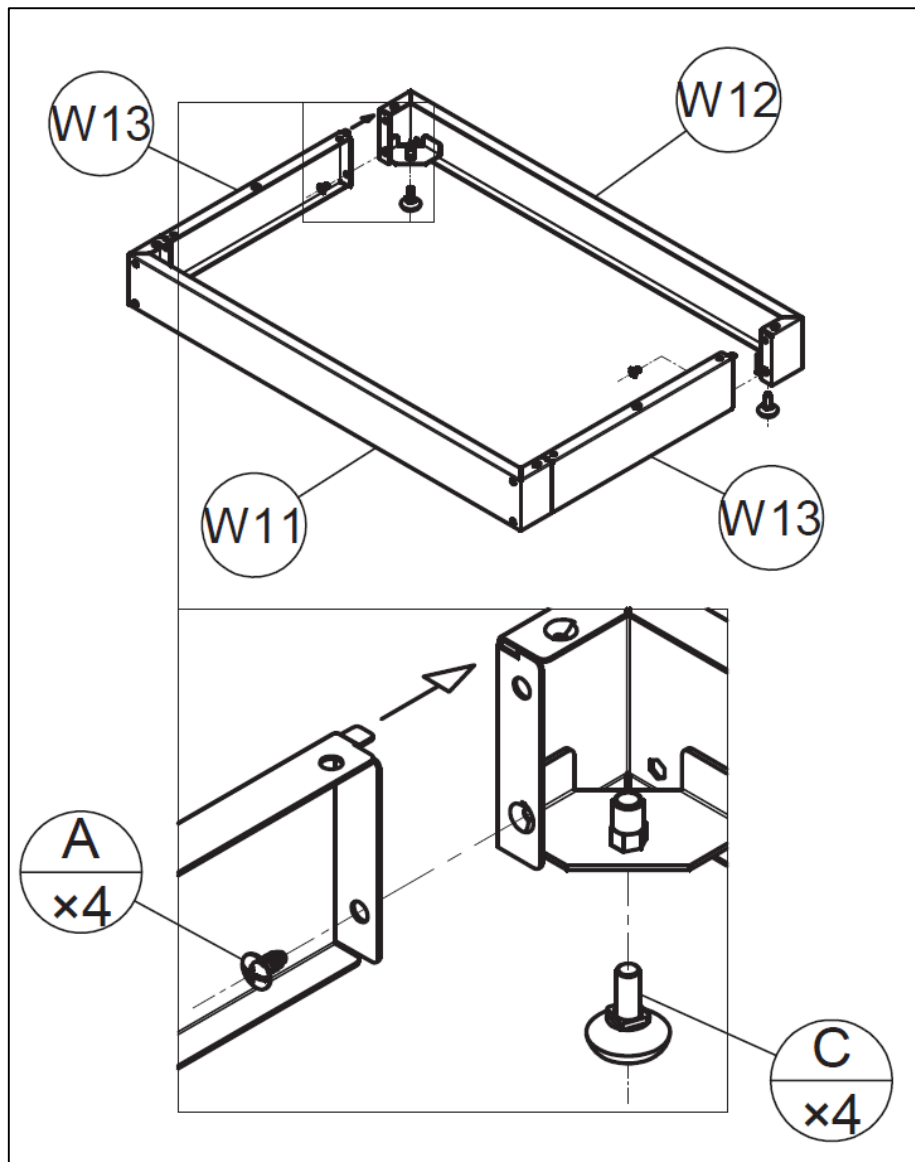

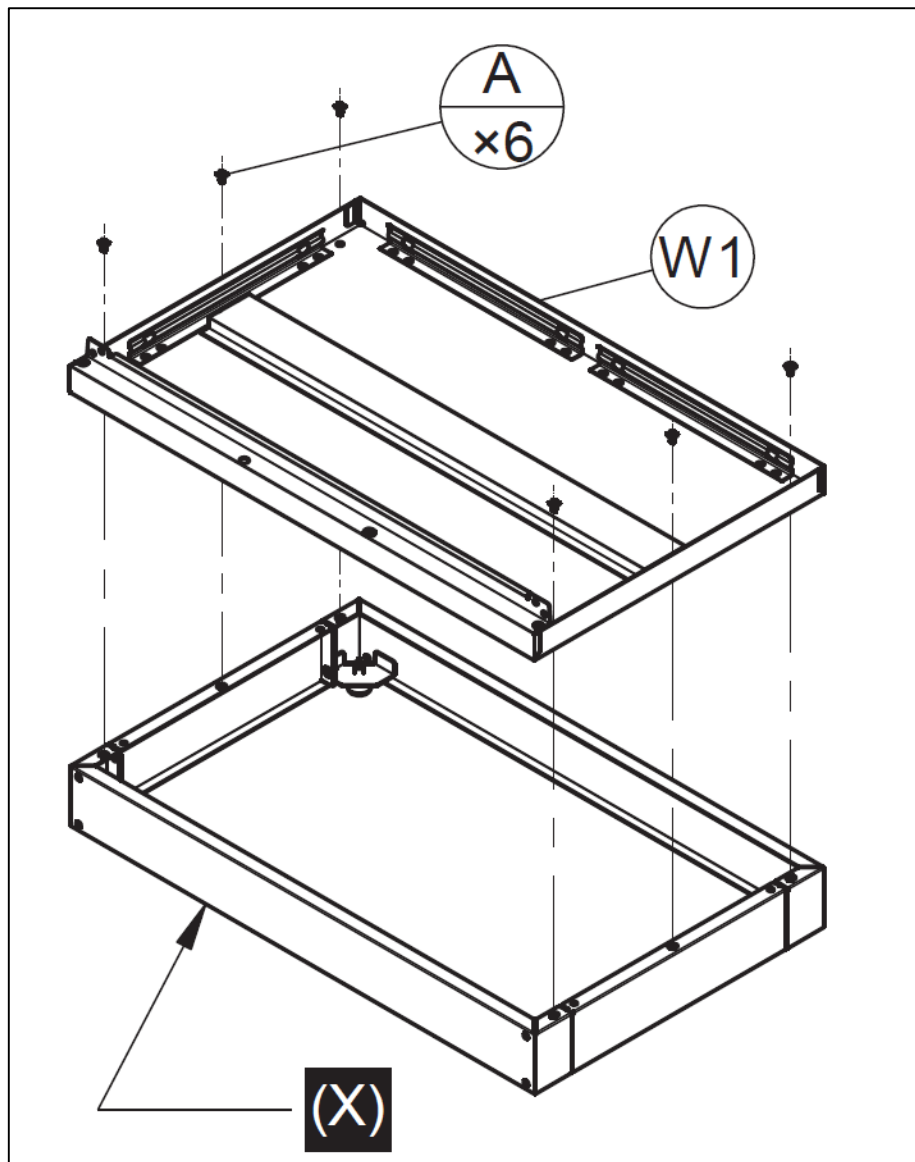

(Y)

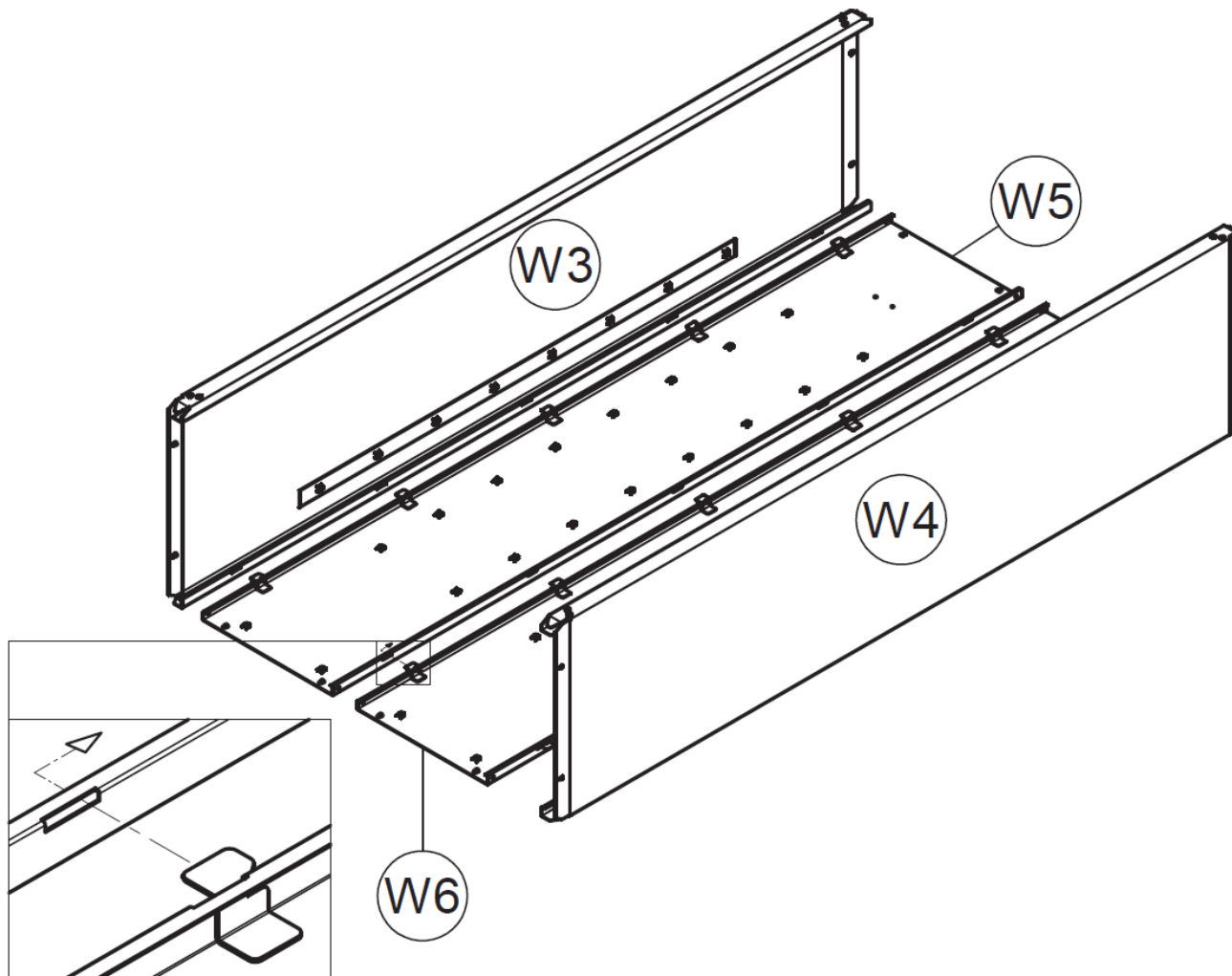

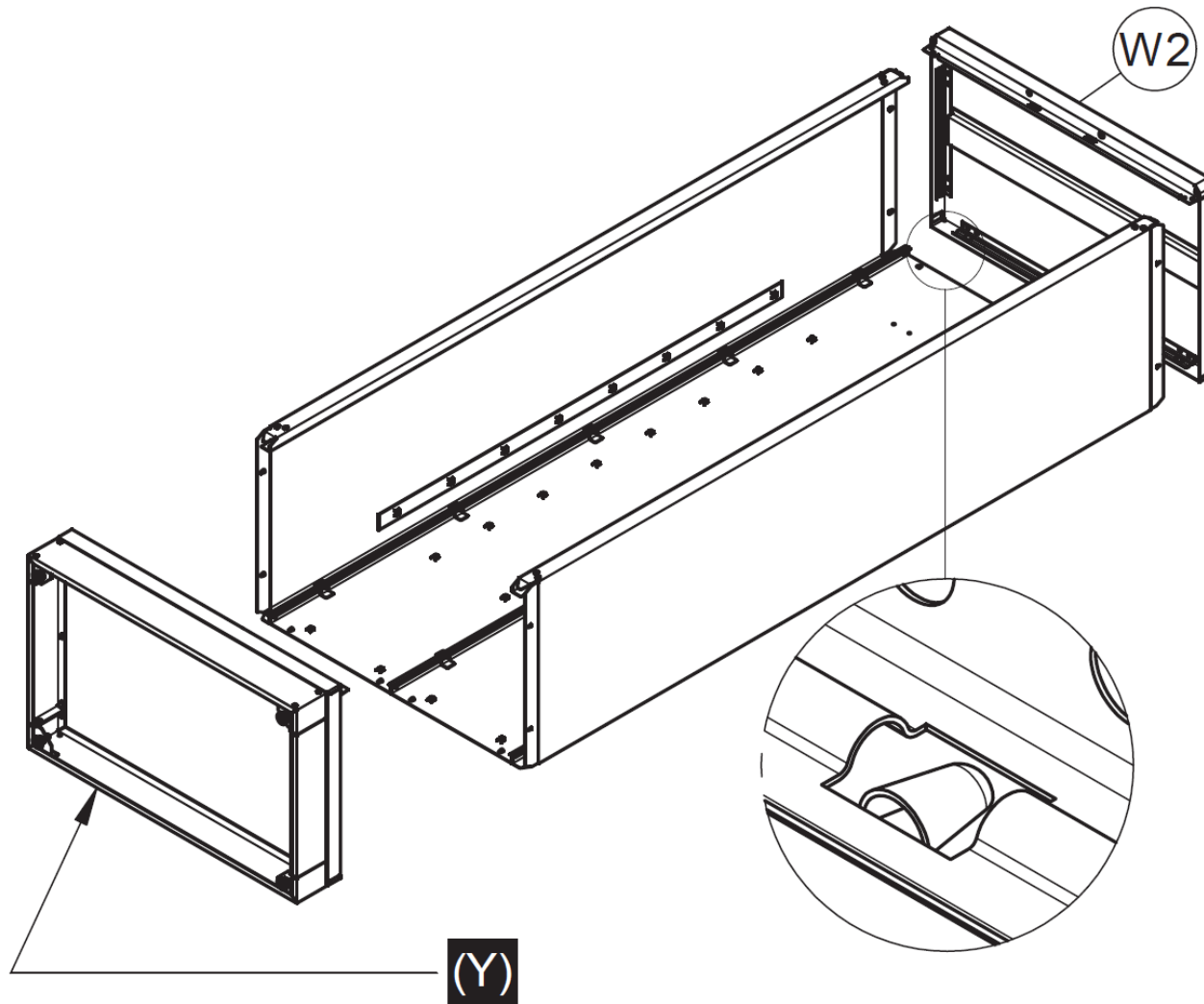

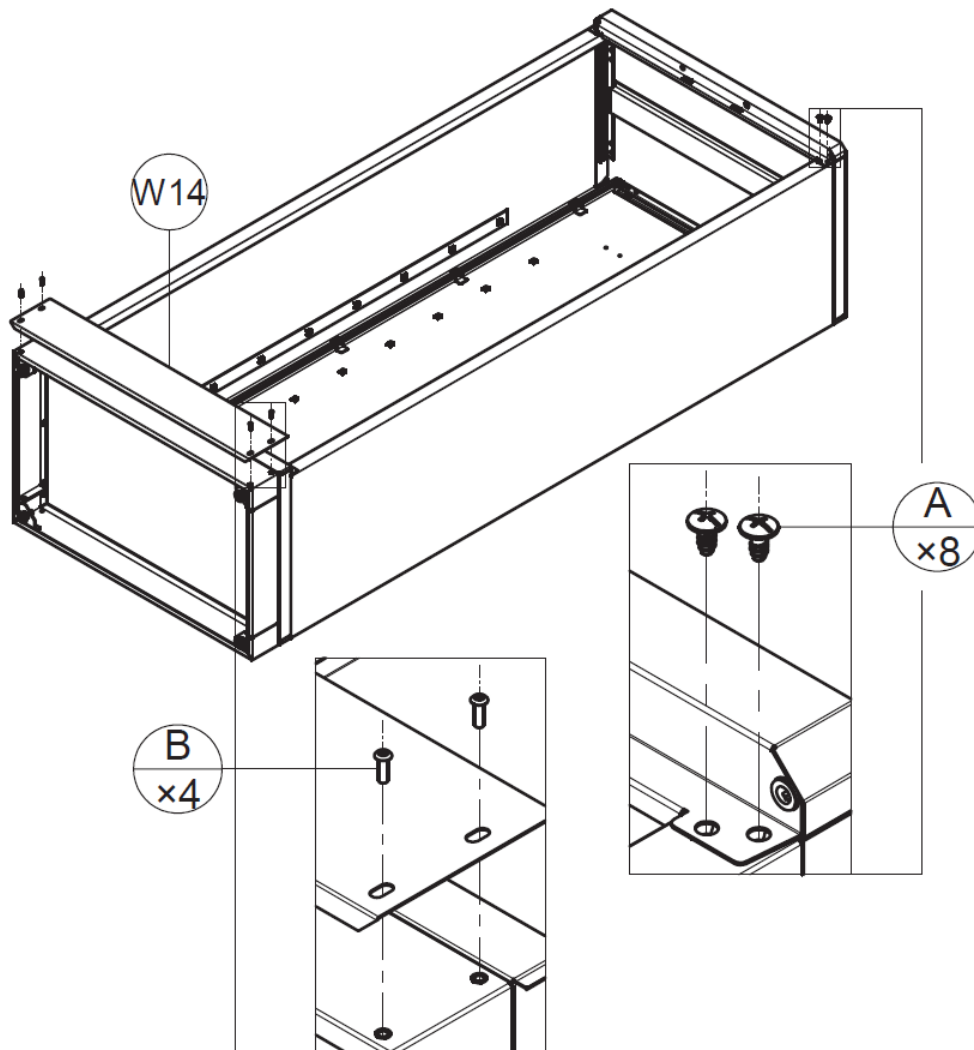

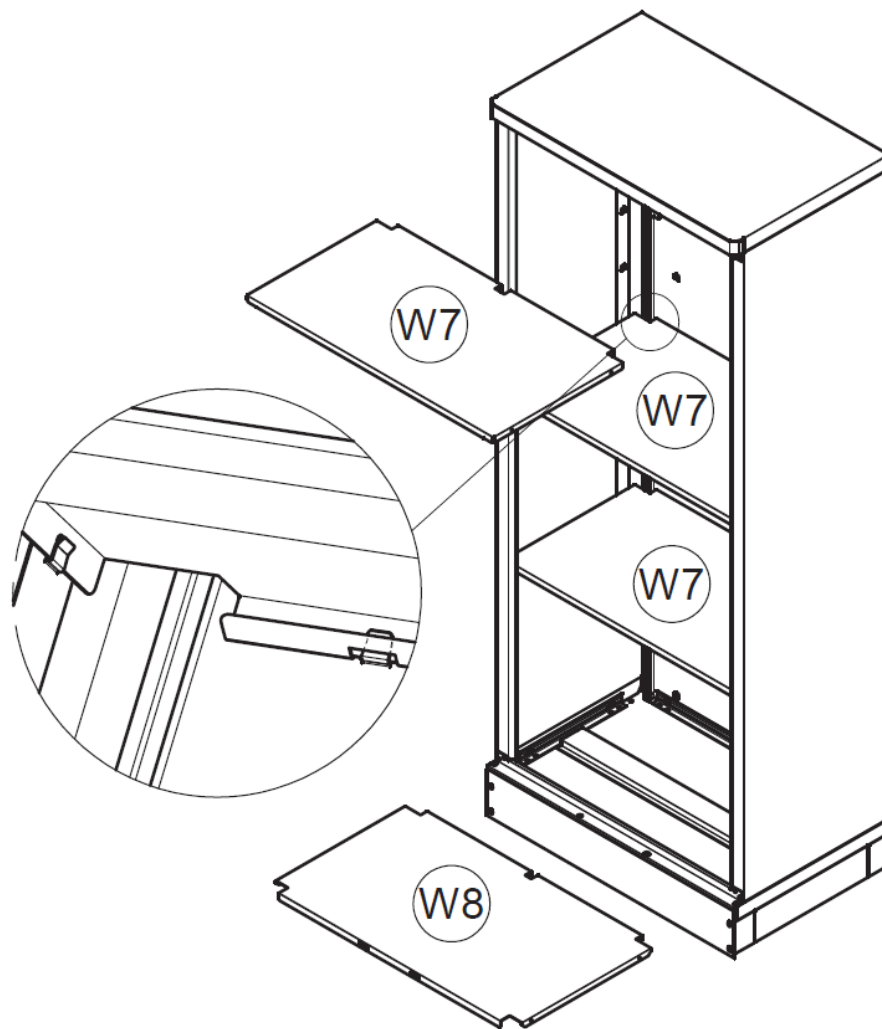

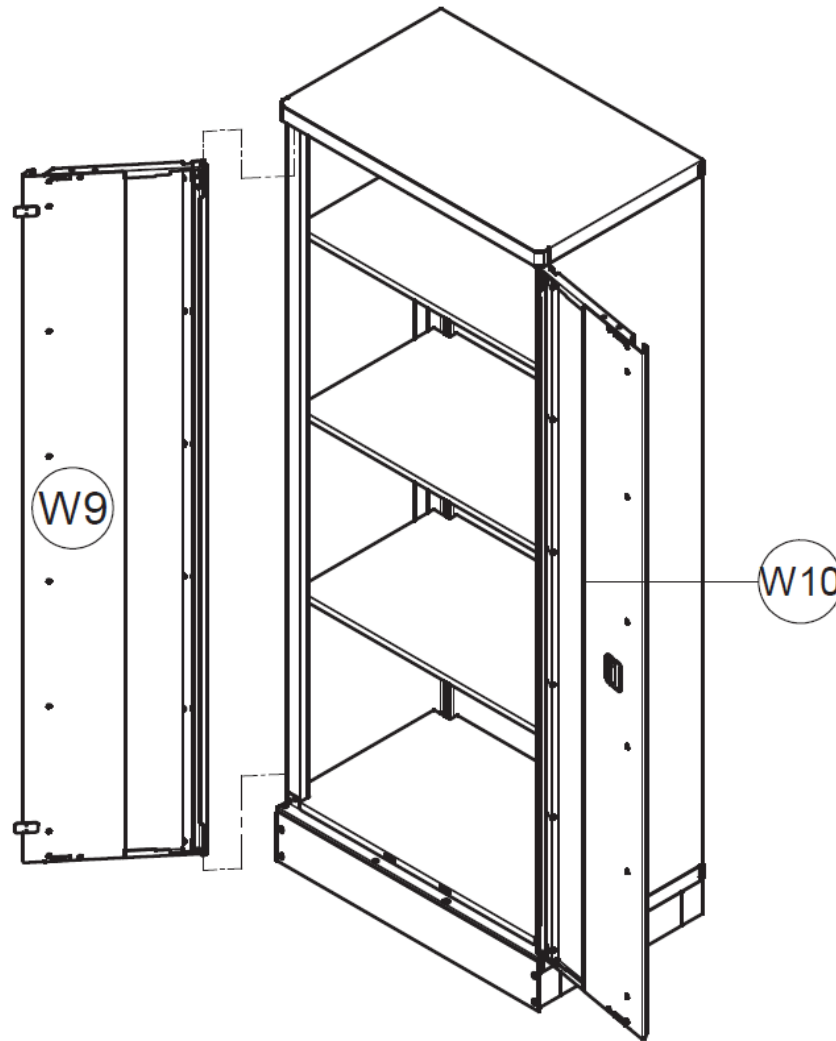

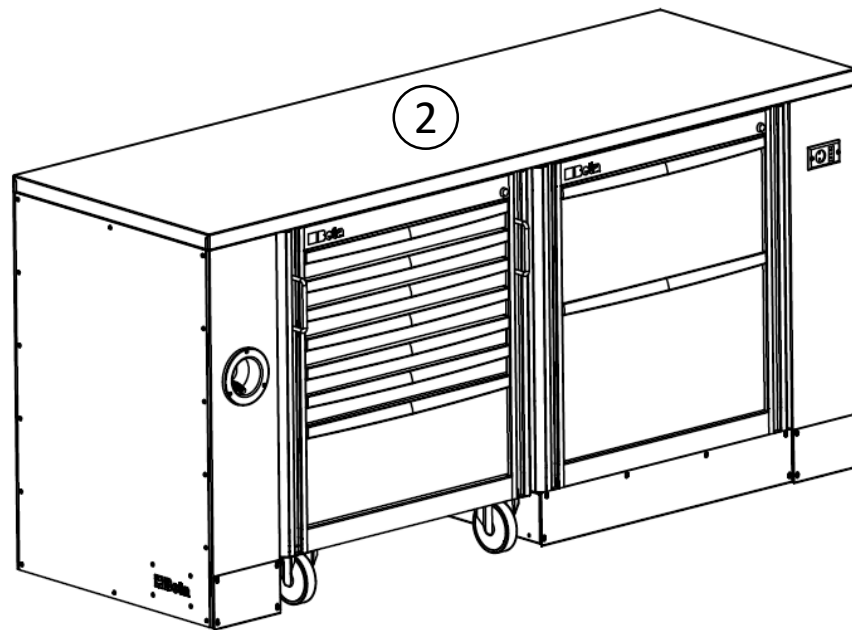
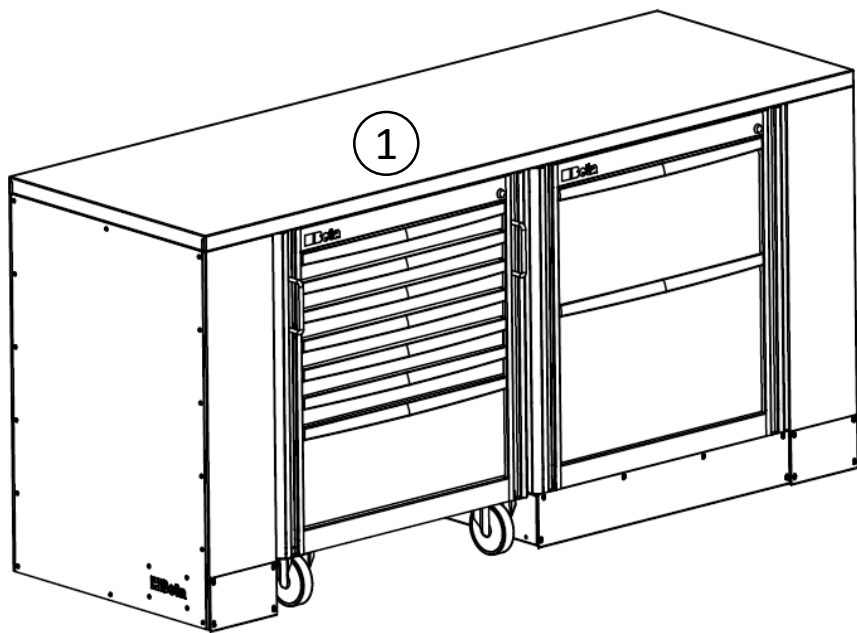





| Pos | Code | Descrizione/ Description | Pcs . |
|-----|-----------|--|-------|
| 1 | 055000101 | BANCO DI LAVORO da 2m / <i>2m workbench</i> | 4 |
| | 055000102 | a) Piano di lavoro 2m/ <i>2m worktop</i> | 1 |
| | 055000104 | b) Gamba destra semplice/ <i>Plain right leg</i> | 1 |
| | 055000105 | c) Gamba sinistra semplice / <i>Plain left leg</i> | 1 |
| | 055000103 | d) Traversa di sostegno posteriore/ <i>Rear support crossbeam</i> | 1 |
| 2 | 055000151 | BANCO DI LAVORO da 2m TIPO PRO/ <i>2m pro workbench</i> | 4 |
| | 055000102 | a) Piano di lavoro 2m/ <i>2m worktop</i> | 1 |
| | 055000154 | b) Gamba destra con arrotolatore aria/ <i>Right leg with built-in roller</i> | 1 |
| | 055000155 | c) Gamba sinistra con presa corrente/ <i>Left leg with power sockets</i> | 1 |
| | 055000103 | d) Traversa di sostegno posteriore/ <i>Rear support crossbeam</i> | 1 |
| 3 | 019010111 | ARROTOLATORE/ <i>Hose reel</i> | 1 |
| 4 | * | CASSETTIERA MOBILE/ <i>Mobile roller cab</i> | N.d |
| 5 | * | MODULO FISSO/ <i>Fixed module</i> | N.d |
| 6 | 015990150 | MORSA DA BANCO/Bench vice | N.d |

*Per selezionare il modello desiderato consultare www.beta-tools.com. Visit www.beta-tools.com for checking all models available

| | | | | | | | |
|------------------------|--|-------------------|--|---------------------------|--|-------------------|--|
| A |  | B |  | C |  | D |  |
| M8 X 16 TCEI (18 pcs.) | | M12 X 60 (3 pcs.) | | Washer Wide Band (6 pcs.) | | Nuts M12 (6 pcs.) | |

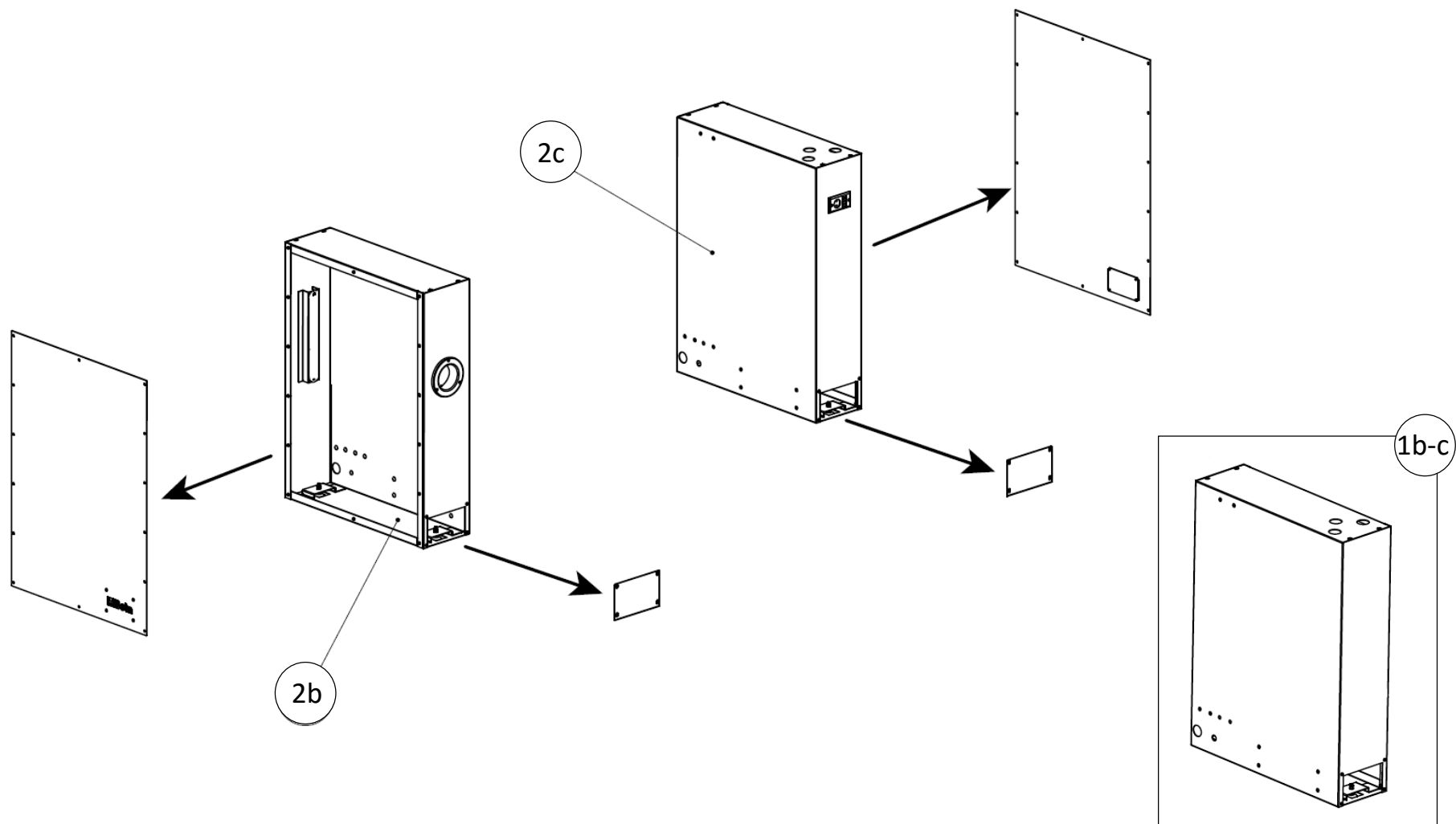

Per ciascuna gamba smontare preventivamente il pannello laterale e lo sportellino anteriore
For each leg remove the side cover and the front window

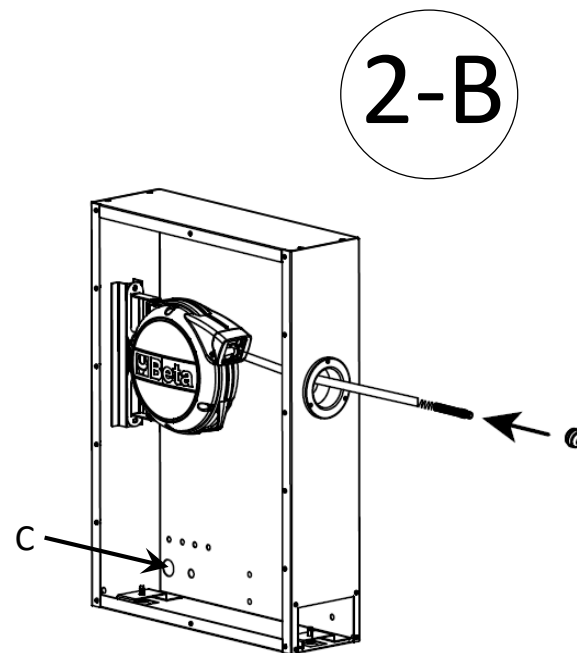
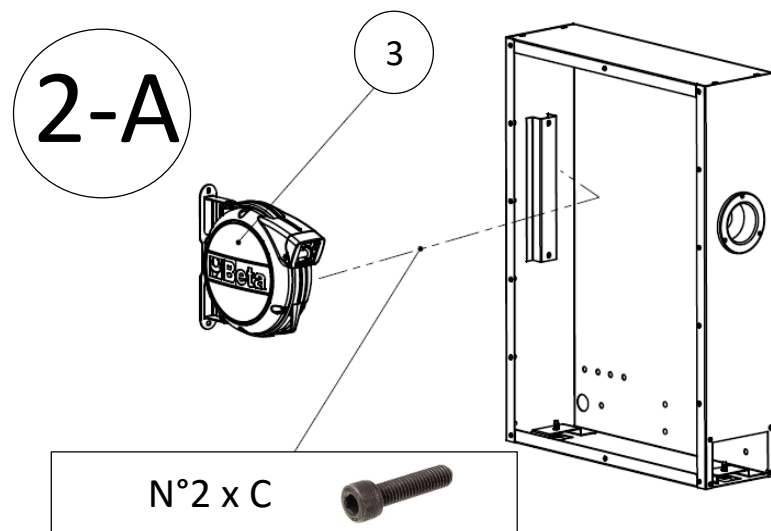

Inserire il tubo dell'aria nell'apposito alloggiamento e far passare l'altra estremità nel foro C
Insert the rollable end of the air hose in the front socket; pass the other one through the hole C

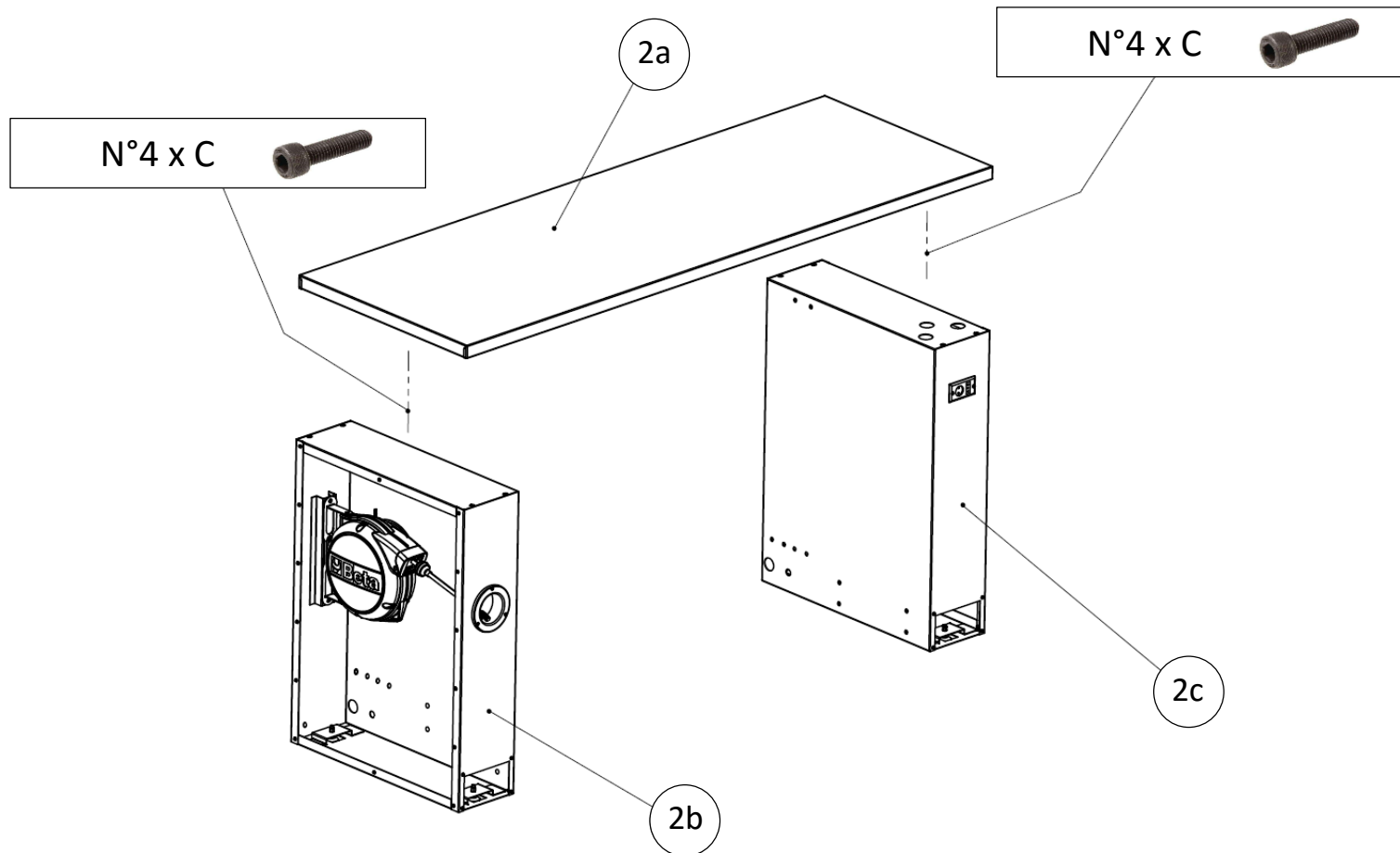

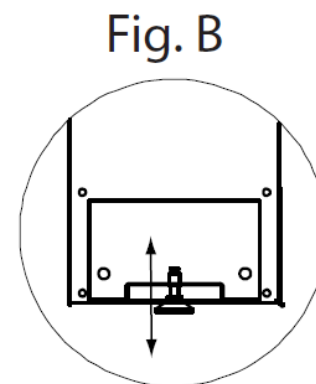
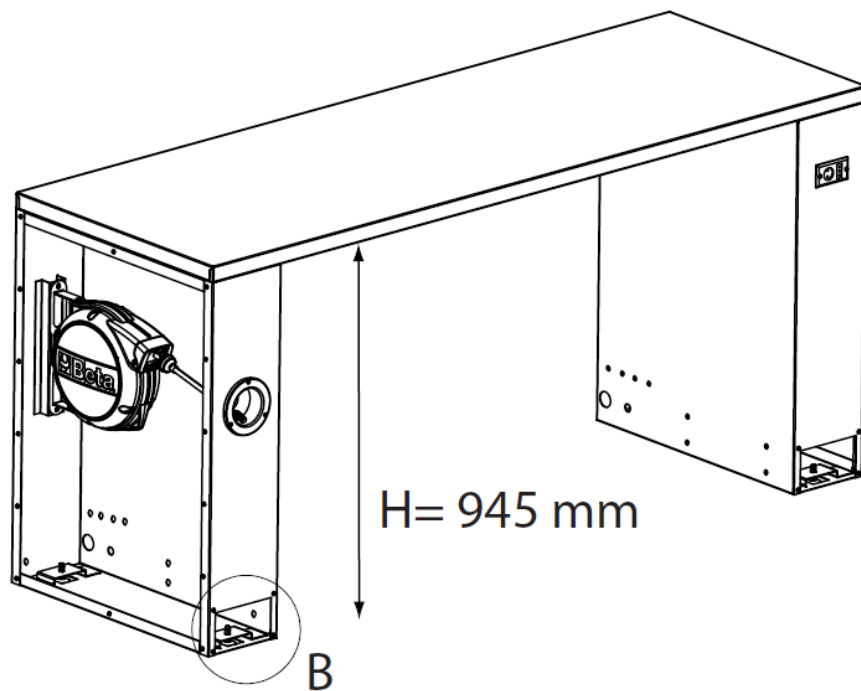

Regolare i 4 piedini (Fig. B) in modo che l'altezza minima del banco da terra sia pari a 945 mm
Adjust the 4 adjustable feet (Fig. B) to level the structure at the minimum height of 945 mm from the floor

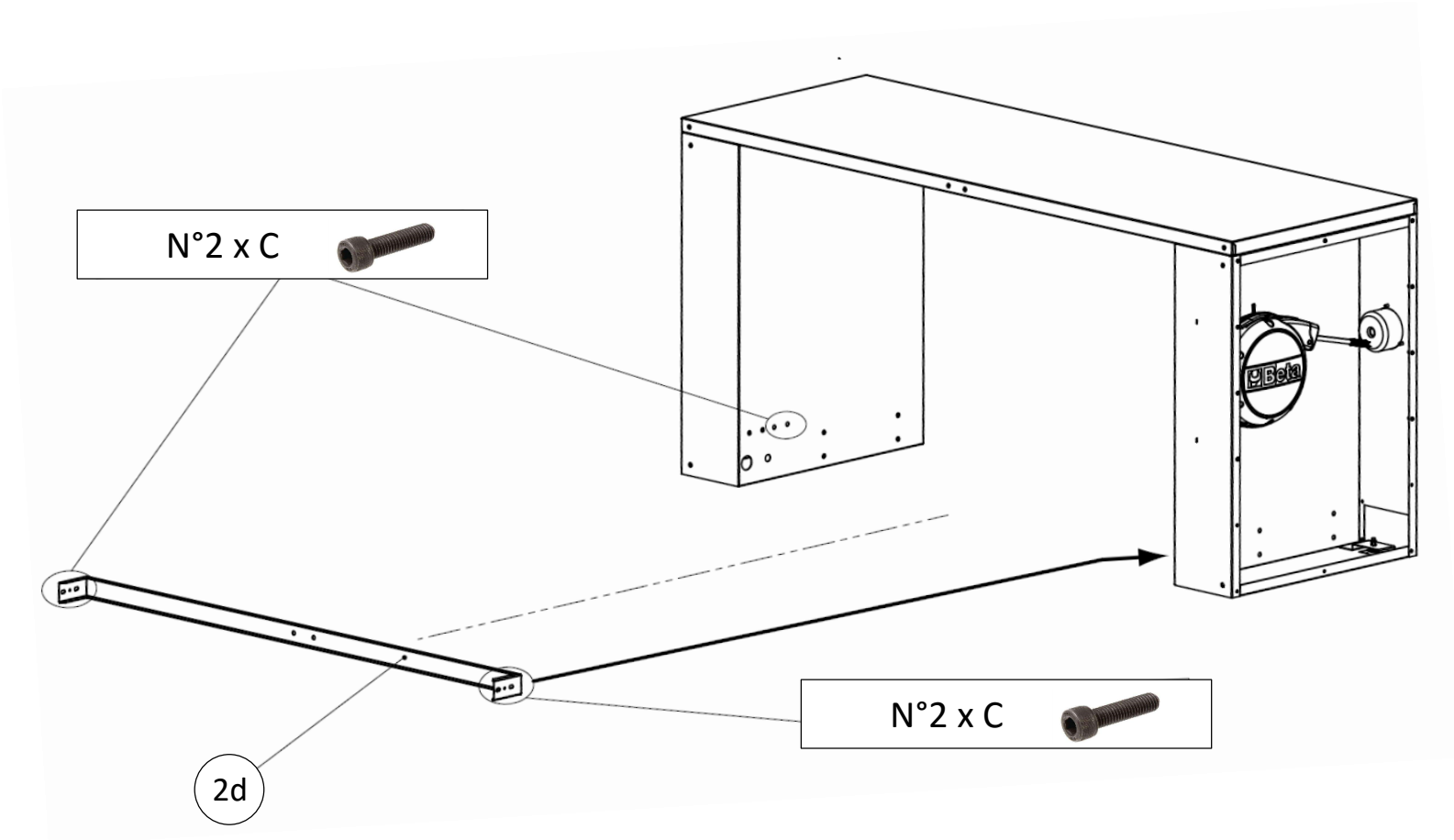

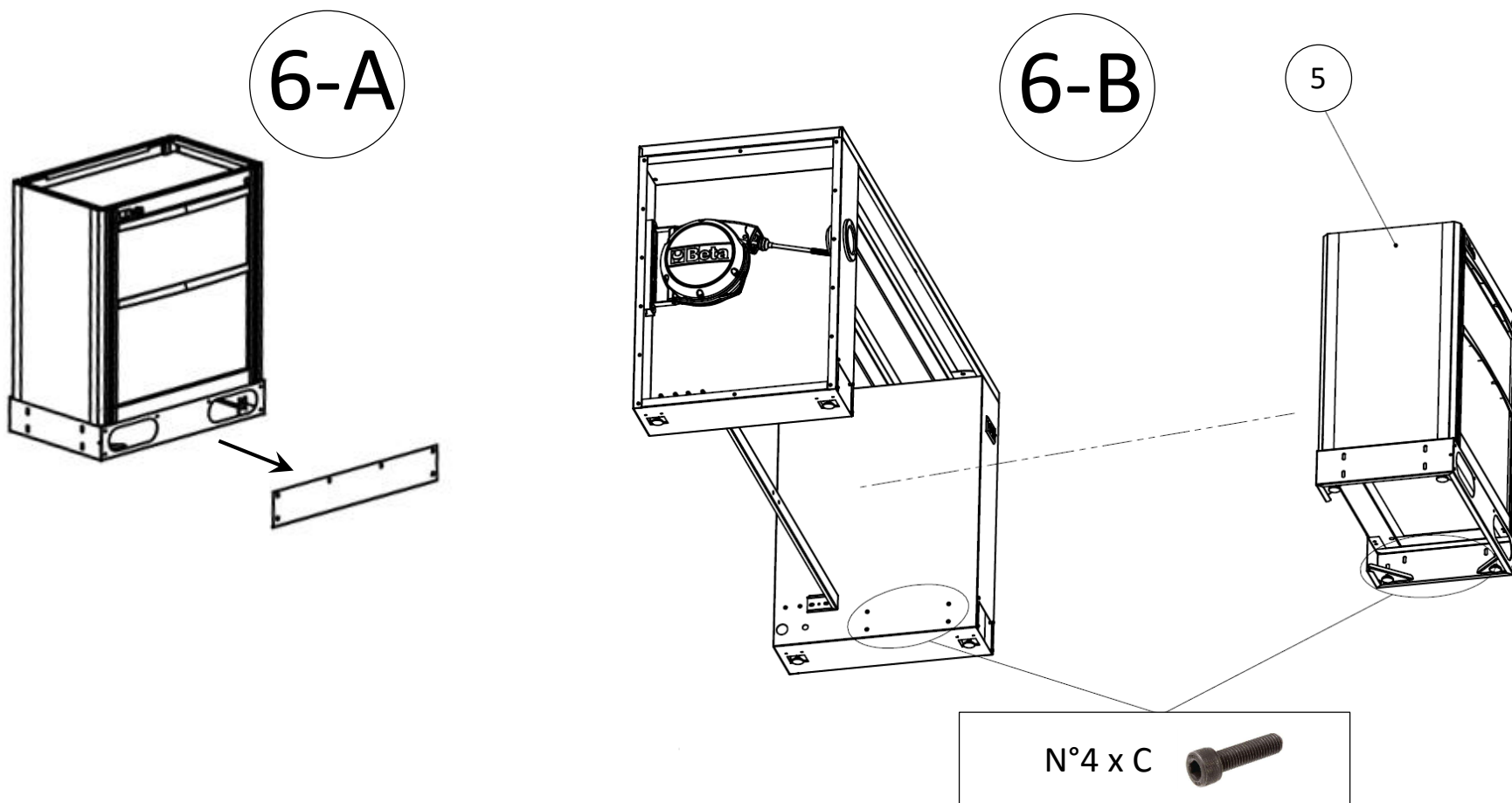

Smontare la cover anteriore del modulo fisso (6-A) e avvitare alla gamba del banco (6-B)
Remove the front cover of the fixed module off (6-A). Screw it the module to the workbench leg (6-B)

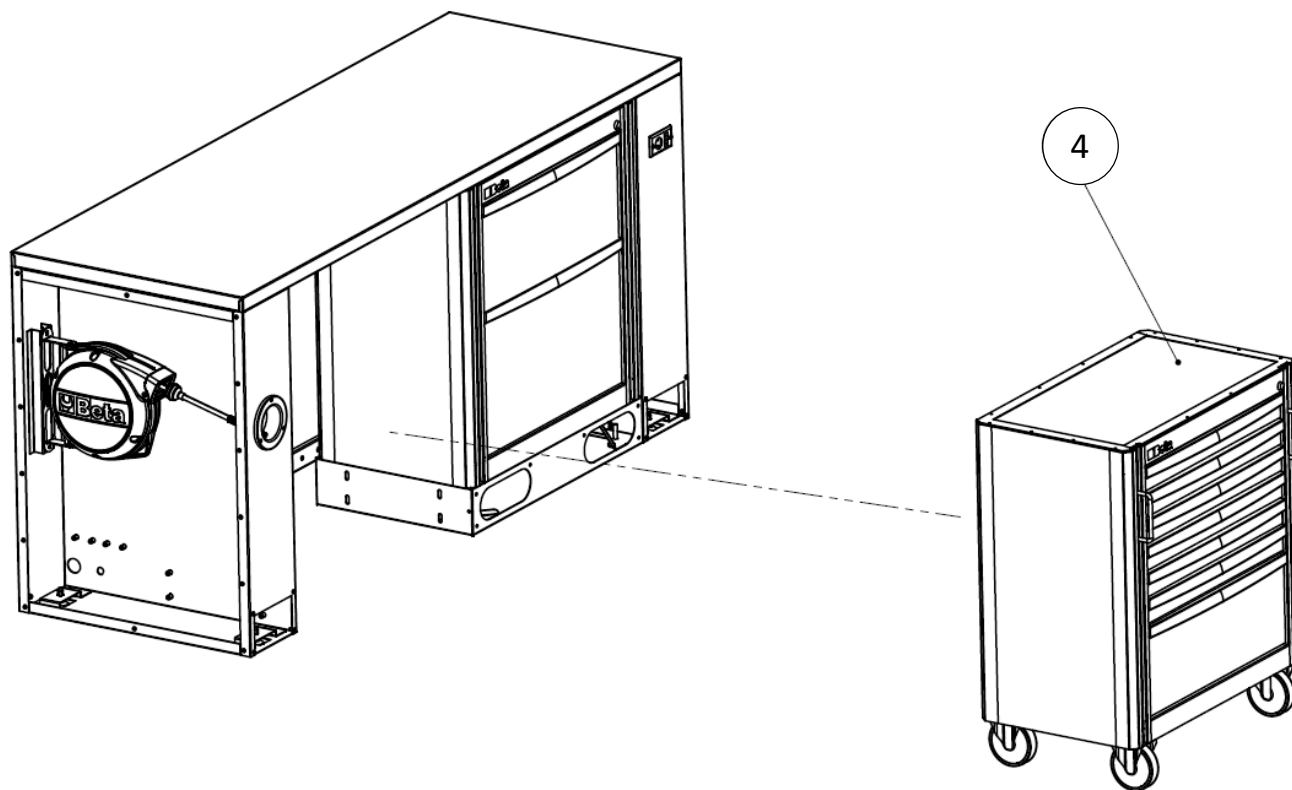

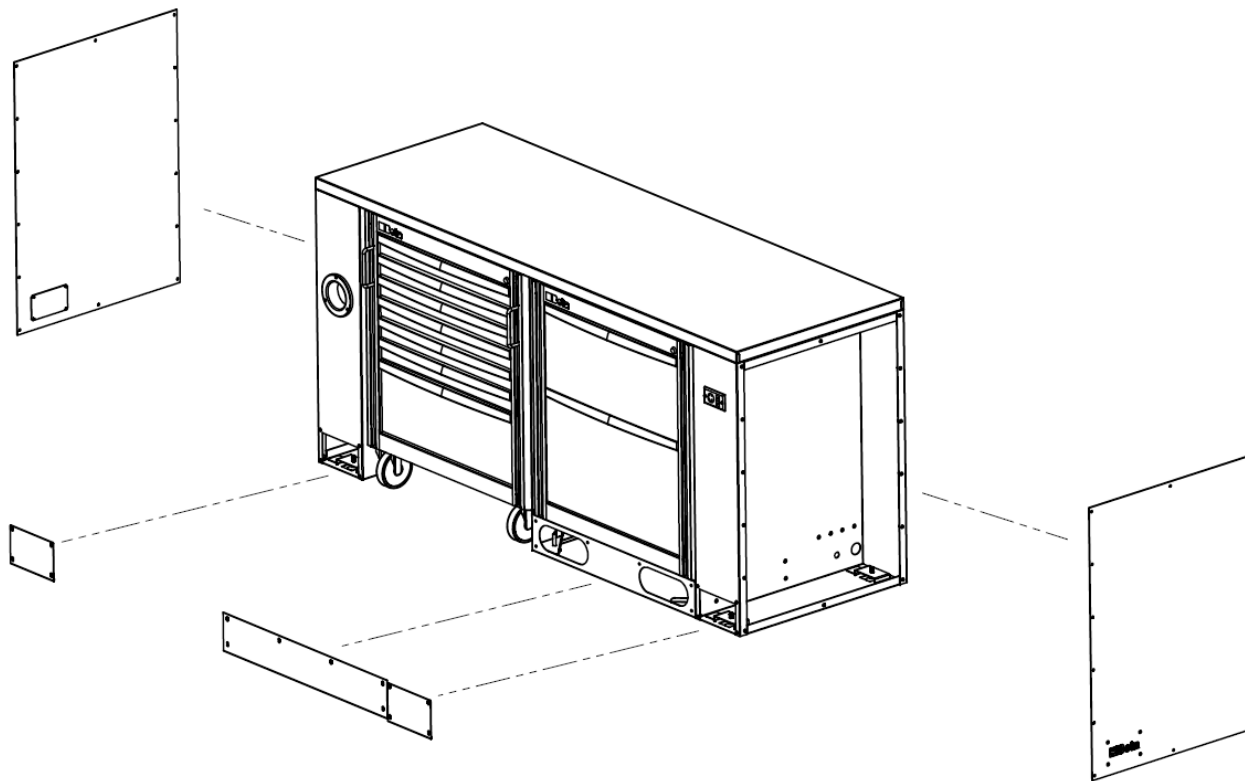

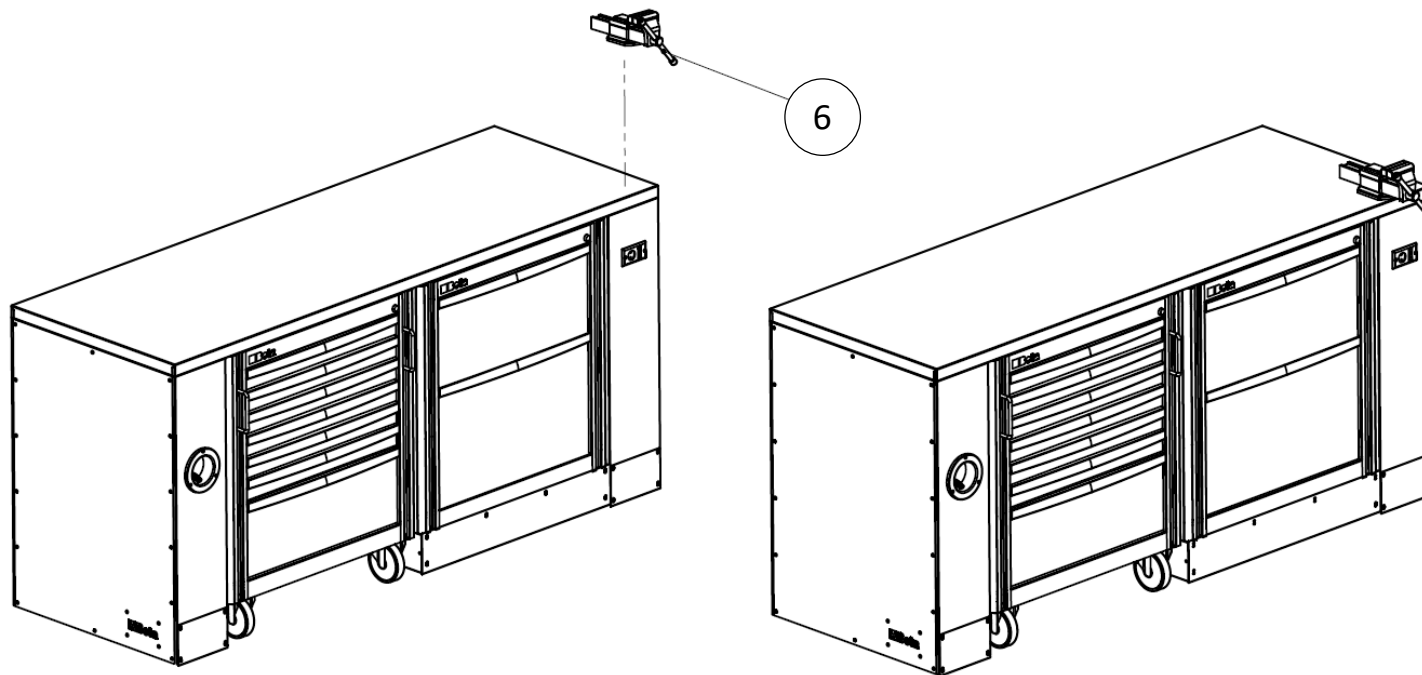

BEFORE

AFTER

9-A

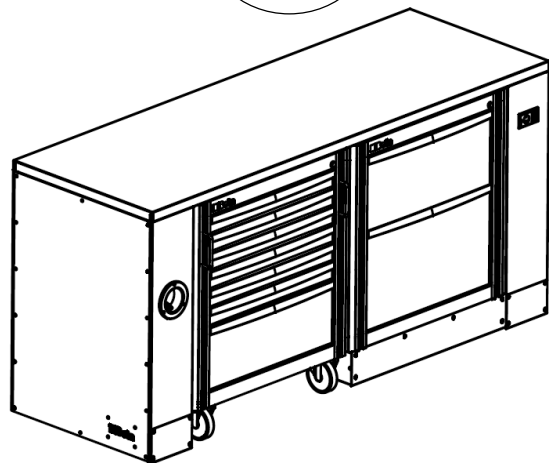

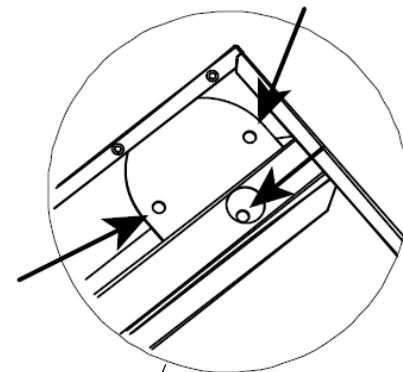
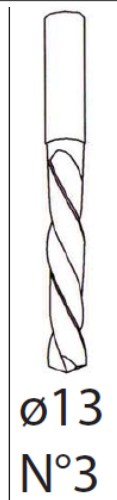
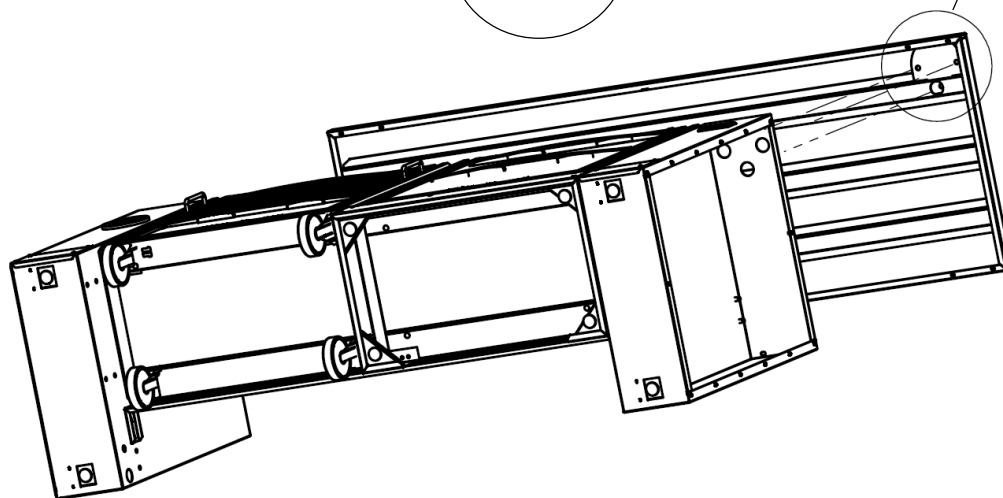

9-B

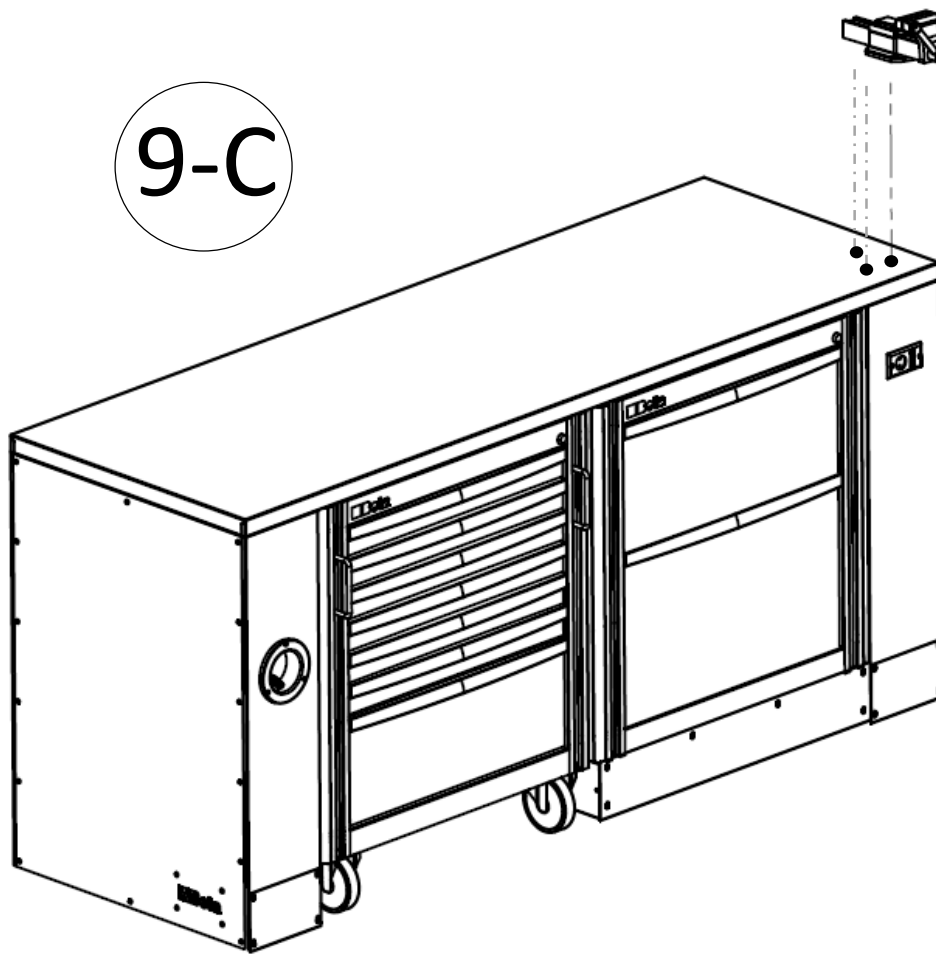

9-C



| | |
|---------|---|
| N°3 x B |  |
| N°6 x C |  |
| N°6 x D |  |